



DAVIES, CRAIG PTY. LTD.
 A.B.N. 71 004 918 825 MELBOURNE
 A.C.N. 004 918 825 AUSTRALIA

77 Taras Avenue
 P.O. Box 363
 Altona North, Vic 3025 Australia
 Phone: +61(0)3 9369 1234
 Fax: +61(0)3 9369 3456
 E-mail: dcfans@daviescraig.com.au
 Web: www.daviescraig.com.au



DUAL FAN MOUNTING BRACKET INSTALLATION INSTRUCTIONS

SUITABLE FOR DAVIES, CRAIG FAN KITS MODELS DC SL8, DC SL9, DC SL10, DC SL12, DC SL14 AND DC SL16

PLEASE READ THESE INSTRUCTIONS FULLY BEFORE YOU START WORK

INTRODUCTION

Congratulations on your purchase of the Davies, Craig Dual Fan Mounting Bracket Kit for your vehicle. This kit is designed to either attach two Davies, Craig Thematic Fans from the range of 8 inch until 14 inch or a single 16 inch high flow fan. The Dual Fan Mounting Bracket Kit offers the freedom to pre-assemble the fans outside the engine bay. It also provides flexible positioning of the complete assembly on to the radiator without the need to connect through the radiator core. If in doubt or if you have any further queries please contact Davies, Craig direct on (03)93691234.

Item No.	Part No.	Description	Qty
1.	0420	Bracket, fan Mounting	2
2.	0423	M5x16 Hex Flanged Screw	8
3.	0424	M5 Square Nut	8



Figure1

ASSEMBLY OF THE FANS

Dual Fan Mounting Kits are reversible and may be mounted either upstream (in front of Radiator/ Condenser) or downstream (on the engine side of the radiator / condenser).

There are five stages involved in the complete installation of Davies, Craig Fan- Bracket assembly

1. Fan-Bracket assembly
2. Installation of fan-bracket assembly
3. Installation of thermal switch (radiator cooling) –**Please refer to the fan Installation Instruction**
4. Wiring –**Please refer to fan Installation Instruction**
5. Setting the thermal switch –**Please refer to the fan installation Instruction**

1. FAN-BRACKET ASSEMBLY

The brackets can be used to make a dual fan assembly from the Davies, Craig fan ranges of 8inch until 14inch or a high flow 16 inch single fan assembly.

1a. DUAL FAN ASSEMBLY PROCEDURE

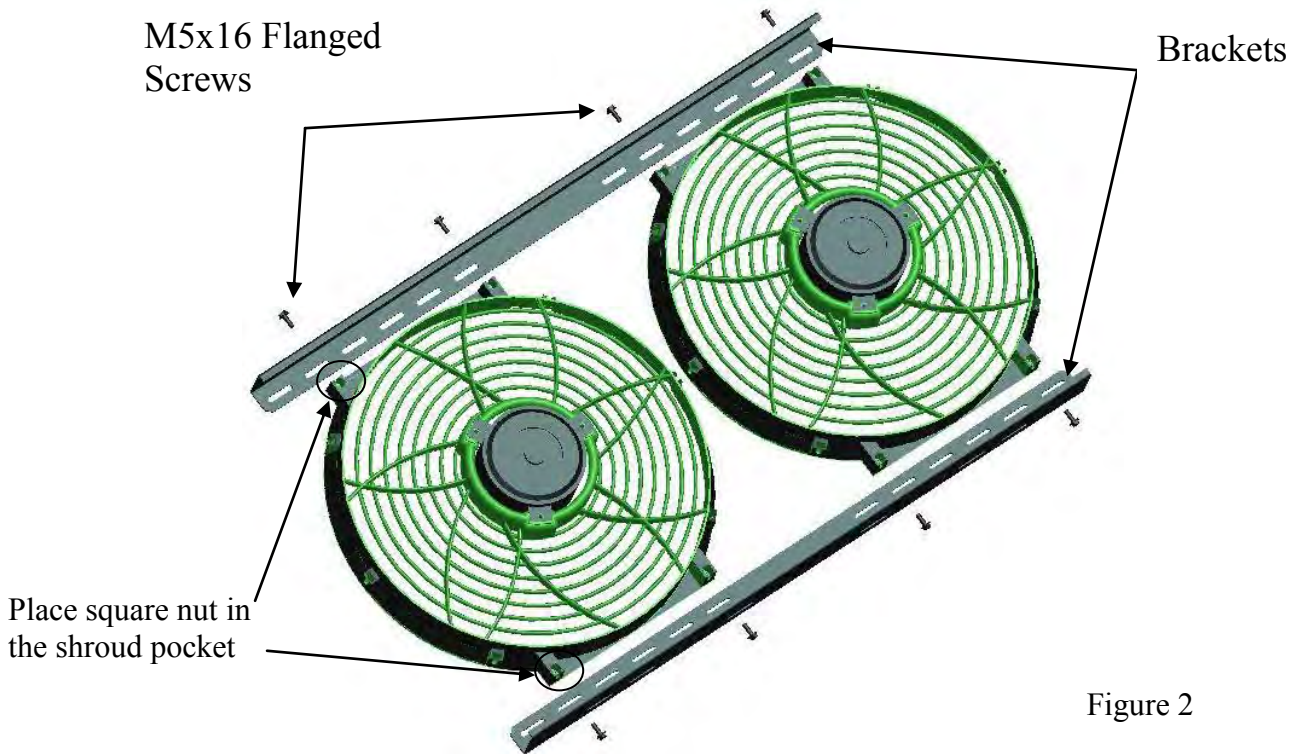

Figure 2

Step 1- Place the bracket and fans on a flat bench as shown in the picture, align the fan shroud with suitable slots on the fan bracket

Step 2- Insert M5 square nut provided in to the pocket on the shroud (ref. figure 2)

Step 3- Hold the nut using a metal strip / flat screw driver to tighten the assembly using the M5 hex. flanged screw provided

Step 4- Repeat the steps 2 &3 above to tighten the remaining screws

1b. SINGLE FAN ASSEMBLY

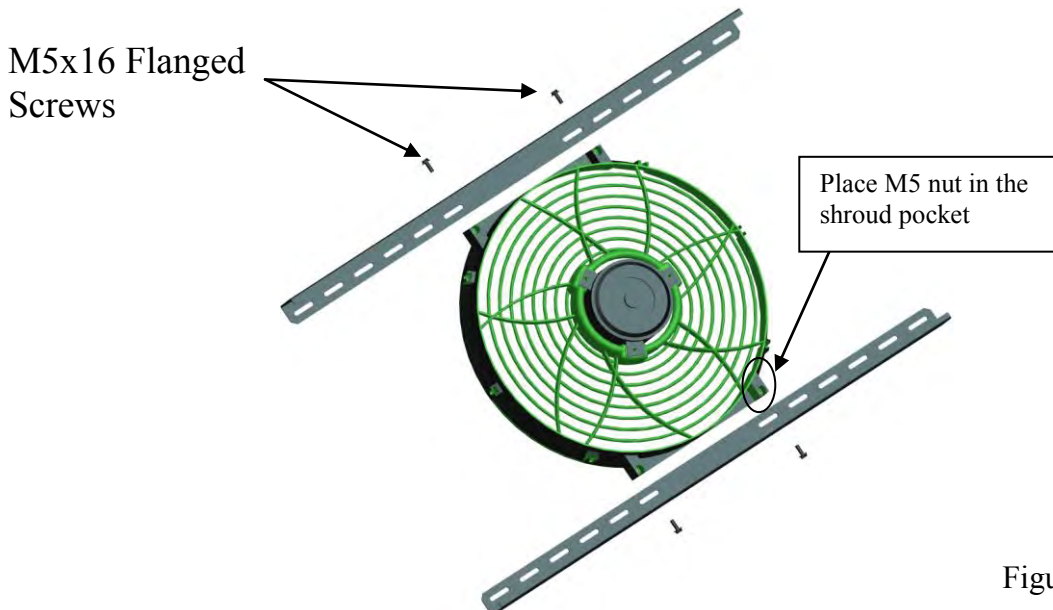

Figure 3

Please apply the same procedure shown above to assemble the single Fan-Bracket assembly

- 1.1 In both cases (1a & 1b), please pay particular attention to the markings on the fan hub regarding the direction the fan should face. This instruction must be followed, whether there is an upstream or downstream mounting.
- 1.2 Please note the direction of the rotation arrow on the hub/blade as once the fan is installed the arrow may not be visible.
- 1.3 For DCSL 8,9,10,12 check that the wires exit the motor downwards (ie. at 6'o clock), so that any condensation formed in the motor will drain.
- 1.4 Spin the fans by hand to ensure free and unobstructed rotation

2. INSTALLATION OF FAN BRACKET ASSEMBLY



Figure 4

- 2.1 Position the unit directly on the face of the radiator/ condenser. Take care that the fan, shroud and brackets does not foul any struts, engine pulleys bonnet latches etc. including when the bonnet is closed.
- 2.2 Fix the bracket(s) to the radiator using long bolts and spring washers (Not provided in the kit) through the slotted hole provided on the bracket face.
- 2.3 Before wiring, spin the fan once again by hand to ensure free and unobstructed rotation.

WARRANTY

We hereby guarantee that for a period of two years from the date of purchase, we shall carry out, free of cost, any repairs that are reasonably necessary to correct any fault in the operation of your Dual Fan Bracket provided that such a fault is directly attributable to a defect in the workmanship or materials used in the manufacture of the part(s) and is not due to installation other than described in these instructions.

DAVIES, CRAIG PTY. LTD.

Warranty registration now available on-line at www.daviescraig.com.au

Date: 04/07/2011

EWP®115 Alloy/Digital Controller Combo 115 litres/min

Part #8050

EWP® ELECTRIC WATER PUMP

Take total control of cooling your engine

- ✓ *more power*
- ✓ *more cooling*
- ✓ *increase fuel efficiency*
- ✓ *world-leading technology*
- ✓ *extend engine life*
- ✓ *universal fit*
- ✓ *lightweight alloy*

2 YEAR WARRANTY

Turbocharge your engine's cooling system with an EWP®115 Alloy Electric Water Pump

The revolutionary Davies, Craig **EWP®115** Electric Water Pump is now available in lightweight aluminium.

Designed for universal engine fitment, and with the high-performance pro, sprint, tarmac, circuit and drag racer in mind, the **EWP®115 Alloy** has 1" NPT internal threads at inlet and outlet for neat, tight, dash fitting applications.

All the same exciting features offered on the EWP®115 are here on the street-smart alloy Electric Water Pump.

This rugged alloy electric water pump is designed to replace the engine's existing mechanical water pump. This essential performance accessory increases power

to your vehicle's drive wheels and improves coolant temperature control.

The EWP®115 Alloy is a universal, do-it-yourself, easy installation fitment to engines up to seven litres.

By removing the parasitic power losses of belt-driven water pumps, the EWP®115 Alloy releases up to 10kW (13hp) of extra power, increased torque and fuel savings.

Combine it with the **EWP® & Fan Digital Controller** and the pump continues to run after you've switched off, eliminating "heat soak" and extending engine life.

The EWP®115 Alloy and EWP® & Fan Digital Controller Combination Pack is the most economical way to increase horsepower and save on fuel consumption whilst caring for your engine.