

## PART NO. 8700 – EWP MOUNTING BRACKET INSTRUCTIONS

**BEFORE BEGINNING INSTALLATION, PLEASE READ THESE INSTRUCTIONS FULLY.**

### Installation of EWP Mounting Bracket

1. Before installing the EWP and the Mounting Bracket, ensure you have enough space available for the assembly in the engine bay. Note that the EWP works best when located low and close to the radiator hose.
2. Take the detached EWP and the Rubber Damper from the Mounting Bracket Set.
3. Loop the Rubber Damper through the EWP outlet and place it so that the rubber tabs fit against the top of the rim of the EWP base.

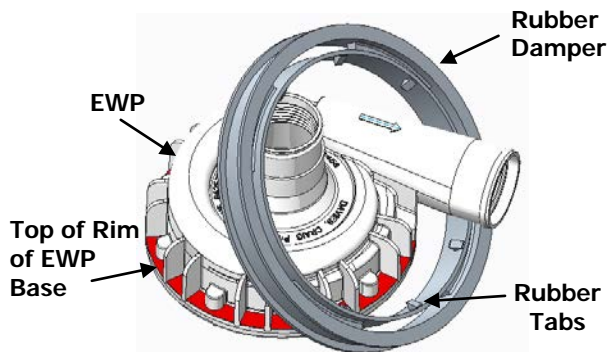

4. Now the Rubber Damper is in place, take the steel ring and place it over the Damper and ensure it fits securely within the rubber groove.

5. Check the rubber tabs are still sitting flat on the EWP surface. Readjust the Rubber Damper if needed.
6. Take the bolt provided and thread it through the two facing holes. Secure tightly with the provided nut.

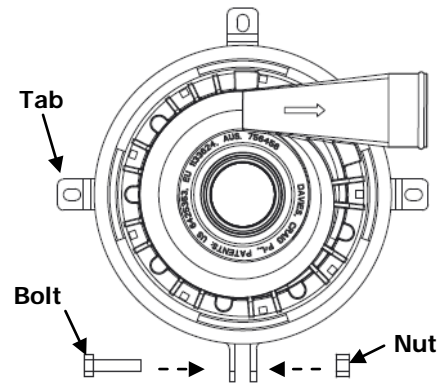

7. Now connect the Bracket to your engine bay by means of the three tabs on the Bracket Ring (Mounting Screws not provided). Reference your EWP installation instructions to ensure correct orientation.

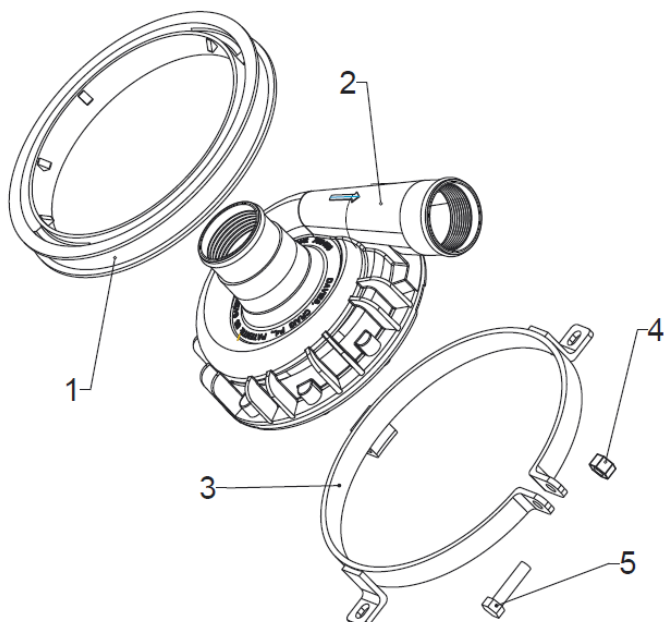

	Part Name	Part Number	Quantity
1	Rubber Damper	18701	1
2	Davies, Craig EWP	(Various)	Not Supplied
3	Steel Ring	18702	1
4	Nut Nyloc 3/16	0529	1
5	Bolt Hex 1 3/4 x 3/16	0502	1

