

VARIABLE SPEED THERMATIC® FAN & EWP CONTROLLER INSTALLATION INSTRUCTIONS

**PLEASE READ ALL THESE INSTRUCTIONS THOROUGHLY BEFORE YOU START WORK.
DON'T RUSH - ENSURE YOU HAVE FULL UNDERSTANDING OF THE WORK AHEAD BEFORE YOU COMMENCE.**

COMPONENTS - #0555

- ⊕ 1 x Variable Speed Thematic® Fan & EWP Controller
- ⊕ 1 x Temperature Probe Mounting Kit
- ⊕ 1 x Temperature Probe
- ⊕ 1 x ¼" NPT Thermal Sensor Kit
- ⊕ 2 x Yellow 6mm Ring Terminal
- ⊕ 4 x Red 3.5mm Fork Terminal
- ⊕ 4 x Yellow Connectors
- ⊕ 1 x Self-Tapping Screws



COMPONENTS - #0556

- ⊕ 1 x Variable Speed Thematic® Fan & EWP Controller
- ⊕ 1 x Temperature Probe Mounting Kit
- ⊕ 1 x Temperature Probe
- ⊕ 1 x ⅛" NPT Thermal Sensor Kit
- ⊕ 2 x Yellow 6mm Ring Terminal
- ⊕ 4 x Red 3.5mm Fork Terminal
- ⊕ 4 x Yellow Connectors
- ⊕ 1 x Self-Tapping Screws

Product Overview

The Variable Speed Thematic® Fan & EWP Controller is a high-performance control unit designed to optimise thermal management in automotive, industrial, marine, and EV applications. It provides intelligent, precise control of dual cooling fans or Electric Water Pumps (EWP®), ensuring maximum efficiency, system protection, and reliable operation in demanding environments.

Key Features

Flexible Operating Modes

- ⊕ The controller offers four distinct control modes to suit different cooling system applications. Each mode is optimised for specific applications, allowing the user to balance responsiveness, efficiency, and noise.

Independent Dual Outputs

- ⊕ Two fully isolated channels allow separate control of fans or pumps.
- ⊕ Unique setpoints, and operating modes can be applied to each output independently.

Shutdown Control

- ⊕ After ignition-off, the controller can keep fans running for a user-defined time or until a defined shutdown temperature is reached, ensuring effective heat soak management.

Manual Overrides

- ⊕ Dedicated ON/OFF control per channel bypasses automatic control if needed.
- ⊕ Configurable polarity accommodates different wiring and switch arrangements.

Safety & Failsafe Operation

- ⊕ In the event of a sensor fault, outputs default to full speed to protect the system.

Advanced Configuration Options

- ⊕ **Temperature Difference:** Defines ramping start relative to the base setpoint.
- ⊕ **Start Speed:** Defines the Speed at which the fan will start
- ⊕ **Shutdown Time & Temperature:** Controls post-ignition cooldown time and temperature.
- ⊕ **Temperature Offset:** Adjusts for sensor calibration.
- ⊕ **Factory Reset:** Restores all parameters to default.

Rugged, Reliable Design

- ⊕ IP67 waterproof rating ensures durability in harsh environments.
- ⊕ Heavy-duty 40A Current draw limit per Fan supports high-performance cooling systems.

CONTROLLER INSTALLATION AND WIRING INSTRUCTIONS

CONTROLLER MOUNTING

Mount the Controller in the engine bay, in a convenient location using the self-tapping screws provided.

- **Temperature Sensor wire MUST NOT be cut in ANY circumstances.**
- Ensure the mounting location allows easy access to the set button.
- Keep unit away from high heat sources, such as exhaust manifolds etc.

TEMPERATURE SENSOR INSTALLATION

OPTION 1: TEMPERATURE PROBE INSTALLATION

Requires access to the front and rear face of the radiator. Remove the radiator and/or condenser, if necessary.

The Temperature Probe MUST NOT be installed underneath the radiator hose in the coolant.

- ⊕ Select a Temperature Probe mounting location that will not interfere with the fan/s.
 - For optimum performance, install the Temperature Probe as close to the hot coolant inlet as possible.
 - The Temperature Probe must **not** extend through the radiator core as this will affect the switch's operation.
- ⊕ Remove the backing paper from foam pad. Slide the foam pad onto the quick mount rod so the pad adheres to the head of the quick mount rod.
- ⊕ Gently separate the radiator fins where you propose to insert the temperature probe
 - A small screwdriver can assist with this.
- ⊕ Insert the quick mount rod between the separated fins. Push the locking button and sensor onto the quick mount rod to sit flush with the face of the radiator. Cut off excess quick mount rod.

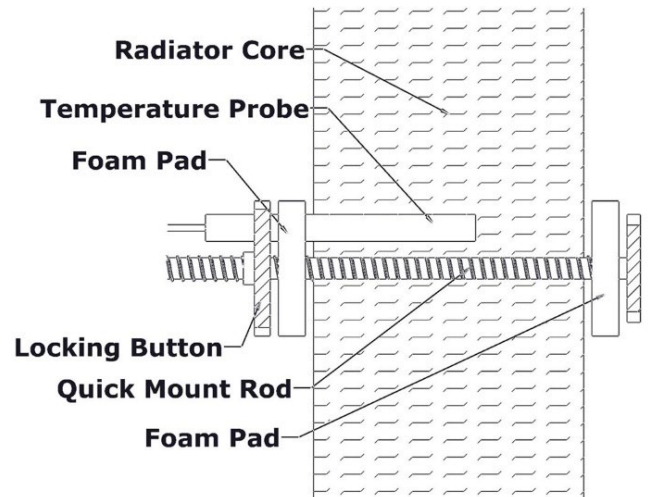

Installing the Temperature Probe directly into coolant requires either part #0409, #0408 OR #0418 (NOT SUPPLIED).

OPTIONAL: INSTALLING TEMPERATURE PROBE INTO THE TOP HOSE REQUIRES #0409 OR #0408 (NOT SUPPLIED).

- ⊕ To install the Probe, follow the instructions provided with the #0409 or #0408 kit

If you would prefer to measure the coolant temperature directly using a port in the thermostat housing, engine block, or directly into the radiator, we recommend using one of our brass sensors Part #0465 (1/4" NPT), #0468 (1/8" NPT) or #0462 (M12 x 1.5).

For #0555 Part #0465 is Supplied. For #0556 Part #0468 is Supplied.

Part #0465: 1/4" NPT Thermal Sensor Upgrade Kit



OPTION 2: 1/4" NPT THERMAL SENSOR INSTALLATION

#0555 1/4" NPT Sensor Supplied

#0556 Requires #18415 (Sold Separately).

If you wish to install the Sensor in the top radiator hose, we recommend part #0415, #0417, #0419 or #0416 (Sold Separately).

- ⊕ Unplug the Temperature Probe and plug in the 1/4" NPT Thermal Sensor.
- ⊕ Install the Thermal Sensor into the port, making sure not to over tighten or damage the Thermal Sensor.
 - Thread adapter fittings (not supplied) may be required when using existing ports.
 - When a port is not available, it is possible to drill and tap a hole for locating the Thermal Sensor.
 - You may require some thread tape or sealant to achieve a watertight seal.

Part #0468: 1/8" NPT Thermal Sensor Upgrade Kit



OPTION 3: 1/8" NPT THERMAL SENSOR INSTALLATION

#0555 Requires #18418 (Sold Separately).

#0556 1/8" NPT Sensor Supplied

If you would prefer to install the Thermal Sensor directly into the coolant, use the 1/8" NPT Thermal Sensor.

- ⊕ Unplug the Temperature Probe and plug in the 1/8" NPT Thermal Sensor.
- ⊕ Install the Thermal Sensor into the port, making sure not to over tighten or damage the Thermal Sensor.
 - Thread adapter fittings (not supplied) may be required when using existing ports.
 - When a port is not available, it is possible to drill and tap a hole for locating the Thermal Sensor.
 - You may require some thread tape or sealant to achieve a watertight seal.

CONTROLLER WIRING

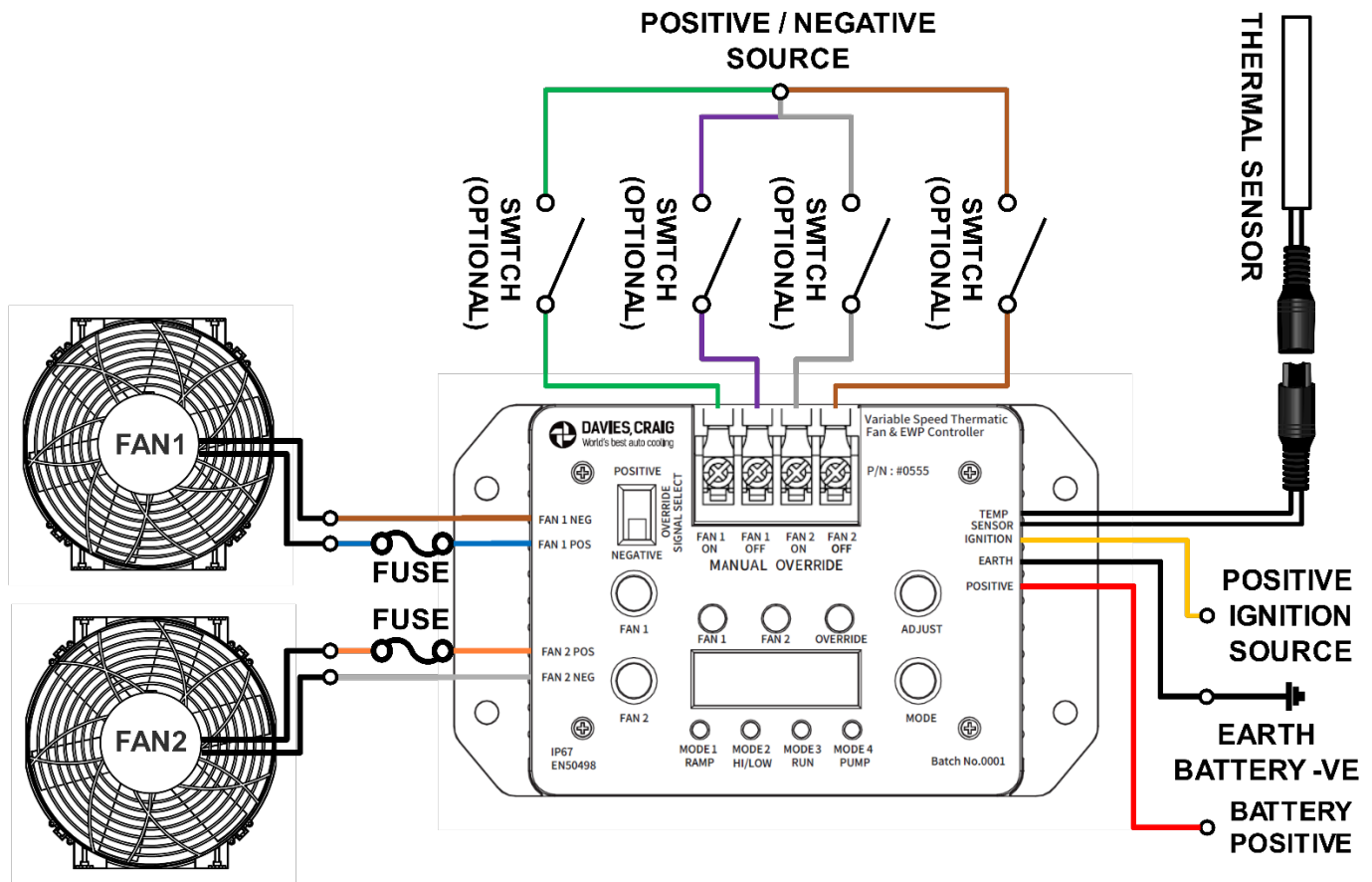

WIRING CONNECTIONS

- ⊕ Connect the **RED** "BATTERY +VE" wire to battery positive.
 - The **RED** Battery wire **does not** need require a fuse as each fan is individually fused.
- ⊕ Connect the **BLACK** "EARTH" wire to the chassis or negative Earth.
 - **For positive earth systems, wire 'Earth' to battery negative not the chassis**
- ⊕ Connect the **YELLOW** "IGNITION" wire to a Positive ignition or accessories source.
 - DO NOT wire to the ECU or the ignition coils as this can cause operational issues
- ⊕ Connect the **BLUE** "FAN 1 POS" wire to the positive wire for Fan 1.
- ⊕ Connect the **BROWN** "FAN 1 NEG" wire to the negative wire for Fan 1.
- ⊕ Connect the **ORANGE** "FAN 2 POS" wire to the positive wire for Fan 2.
- ⊕ Connect the **WHITE** "FAN 2 NEG" wire to the negative wire for Fan 2.

OPTIONAL: Manual Overrides

The controller has 4 optional override terminals to manually force the fans to turn on and off. The polarity (negative or positive) for the manual on and off override connection can be selected using the slide switch. **NOTE: the override signals for Fan 1 and Fan 2 will use the selected polarity.**

The **Manual ON** Override is design to activate the fan for vehicles with A/C or manually using a switch when additional cooling is needed

The **Manual OFF** Override is designed to allow the fans to be shutdown for situation where you do not want the fans to activate, like when performing water crossings or working on the vehicle.

- ⊕ For Air Conditioner overrides, using the provided fork terminals, wire the 'Fan 1 ON' and/or 'Fan 2 ON' terminal to a positive/negative source controlled by the A/C system.
 - For A/C system with a Trinary switch selecting a Negative override signal allows for direct connection to most trinary switches.
- ⊕ For manual on/off overrides, using the provided fork terminals, wire the Fan1/Fan2 overrides to switches located in the vehicle cabin.

ADVANCED CONTROLLER SETTINGS

The Controller has Several Advanced settings that provide further customisation to the fan control for better optimisation cooling performance.

Setting the Temperature difference

The temperature Difference from the base setting for when the fan starts to ramp to full speed

Setting Fan 1 Temperature Difference

- ⊕ Hold '**Fan1 button**' and press the '**Adjust Button**' once to show current setting for Fan 1
- ⊕ Press the '**Adjust button**' again to increment the Fan 1 temperature difference by 1 degree.

Setting Fan 2 Temperature Difference

- ⊕ Hold '**Fan2 button**' and press the '**Adjust Button**' once to show current setting for Fan 2.
- ⊕ Press the '**Adjust button**' again to increment the Fan 2 temperature difference by 1 degree.

Setting Start speed

The speed at which the fan will start running.

Setting Fan 1 Start Speed

- ⊕ Hold Both the '**Adjust button**' and '**Mode Button**' then Press '**Fan1 button**' to change the start speed for Fan 1

Setting Fan 2 Start Speed

- ⊕ Hold Both the '**Adjust button**' and '**Mode Button**' then Press '**Fan2 button**' to change the start speed for Fan 2

Setting the Shutdown Time

The amount of time the unit will stay powered after the ignition is turned off.

- ⊕ Hold '**Adjust button**' and press the '**Fan1 Button**' to increase the Shutdown time by 5 second.
- ⊕ Hold '**Adjust button**' and press the '**Fan2 Button**' to decrease the Shutdown time by 5 second.

Setting the Shutdown temperature

The Temperature difference between the lowest base temperature setting that the temperature needs to be reduced to before the controller turns off.

- ⊕ Hold '**Adjust button**' and press the '**Mode Button**' to increment the shutdown temperature by 1 degree.
- ⊕ The Shutdown temperature can be set to OFF, this means the unit will not run after shutdown.

Adjust the Temperature Sensor Offset

A temperature offset to allow calibration of the sensor to match the OEM/other sensors in the system.

- Hold '**Mode button**' and press the '**Adjust Button**' to increment the temperature sensor offset 1 degree

Perform Factory Reset

Resets all settings for FAN1 and FAN2 back to default value.

- ⊕ Press and Hold All 4 buttons for 5 seconds

FACTORY DEFAULT SETTING

Condition	FAN 1	FAN 2	Setting Range
Base Set Temperature	85°C (185°F)	90°C (194°F)	5°C to 110°C (41°F to 230°F) In single degree increments
Operation Mode	MODE 1	MODE 1	Mode 1 – Mode 4
Temperature difference	5C (9°F)	5C (9°F)	1°C to 40°C (1.8°F to 72°F) In single degree increments
Start Speed	50%	50%	0% to 100% In 5% increments
Shutdown Time	3 minutes		0 to 5 minutes In 5 second, increments
Shutdown Temperature	10C (18°F)		0 to 40°C (0 to 72°F) In single degree increments
Temperature Offset	0C (0F)		+/- 5°C (+/- 9°F)

LED DISPLAY DIAGNOSTIC CHART

Condition		FAN 1 LED	FAN 2 LED	Override LED	Temperature Display
MODE 1 Ramp	Full Speed	GREEN	GREEN	Off	Temperature
	Ramp	GREEN FLASH	GREEN FLASH	Off	Temperature
	Fans Off	OFF	OFF	Off	Temperature
MODE 2 High / low	High Speed	GREEN	GREEN	Off	Temperature
	Low Speed	BLUE	BLUE	Off	Temperature
	Fans Off	OFF	OFF	Off	Temperature
MODE 3 RUN	Full Speed	GREEN	GREEN	Off	Temperature
	Ramp	GREEN FLASH	GREEN FLASH	Off	Temperature
	Low Speed	BLUE	BLUE	Off	Temperature
MODE 4 PUMP	Full Speed	GREEN	GREEN	Off	Temperature
	Ramp	GREEN FLASH	GREEN FLASH	Off	Temperature
	10 Sec On 10 Sec Off	BLUE & GREEN FLASH	BLUE & GREEN FLASH	Off	Temperature
	11 Sec On 30 Sec Off	BLUE	BLUE	Off	Temperature
Errors and warnings	Low Temperature (First 30s)	RED FLASH	RED FLASH	RED FLASH	Temperature
	Over Set Temperature Highest Setting + 10C	RED & GREEN FLASH	RED & GREEN FLASH	N/A	Temperature
	Over Set Temperature Highest Setting + 10C	RED & GREEN & BLUE FLASH	RED & GREEN & BLUE FLASH	N/A	Temperature
	Sensor Short Circuit	RED FLASH	Off	RED	Err1
	Sensor Open Circuit	Off	RED FLASH	RED	Err2

Operating Mode Descriptions

Mode 1 – Ramp

- Fan/pump speed increases proportionally as temperature rises above the defined base setpoint.
- Ramping begins at the Temperature Difference setting below the base temperature, gradually increasing from the configured Start Speed to full speed.
- Ideal for applications requiring smooth, temperature-based modulation to reduce system stress and improve thermal stability.

Mode 2 – High/Low

- Outputs switch between two predefined speeds (low and high) based on temperature settings.
- Provides a simplified two speed control suitable for systems that do not require continuous ramping.

Mode 3 – Run

- Fans/pumps operate at a slow preset speed immediately upon activation.
- Once temperature rises beyond the ramp threshold, output speed increases proportionally to full speed.
- Minimizes abrupt surges and provides gradual system warming, ideal for thermal-sensitive components and intercoolers.

Mode 4 – Pump

- Implements Davies Craig’s proven Electric Water Pump logic for maximum engine or system cooling efficiency.
- Dynamically adjusts output flow to maintain optimal temperature while reducing energy consumption.
- Automatically compensates for changing operating conditions, ensuring consistent system performance.

Manual Override

- Allows to force selected outputs ON or OFF regardless of temperature readings.
- Polarity can be adjusted to match wiring schemes (active-high or active-low), ensuring compatibility with diverse installations.
- Overrides bypass automatic mode control while maintaining system safety features.

Shutdown Mode

- After ignition-off, fans/pumps continue running for a configurable Shutdown Time or until the Shutdown Temperature is reached, whichever occurs first.
- Provides effective heat soak management to protect components and maintain safe operating conditions.

Failsafe Operation

- In the event of a sensor fault or failure, outputs default to full speed.
- Ensures maximum cooling is maintained to prevent overheating and protect the system from damage.

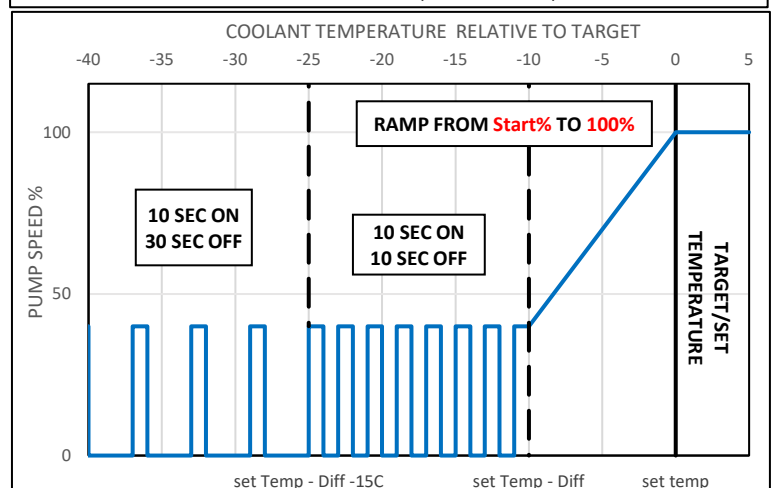
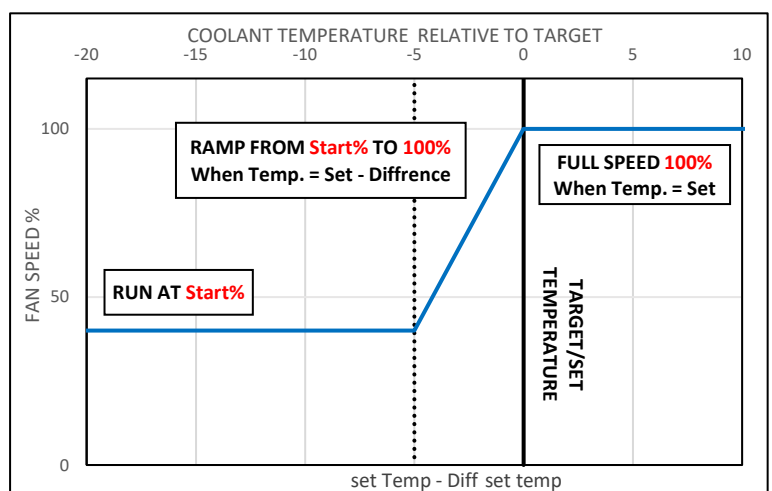
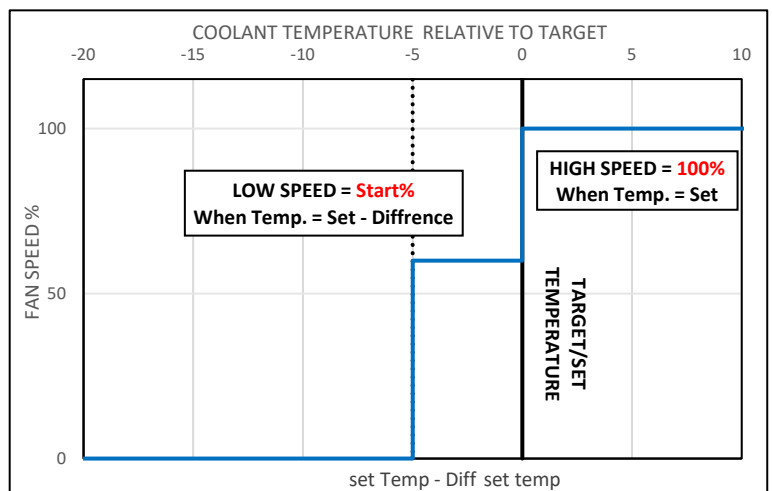
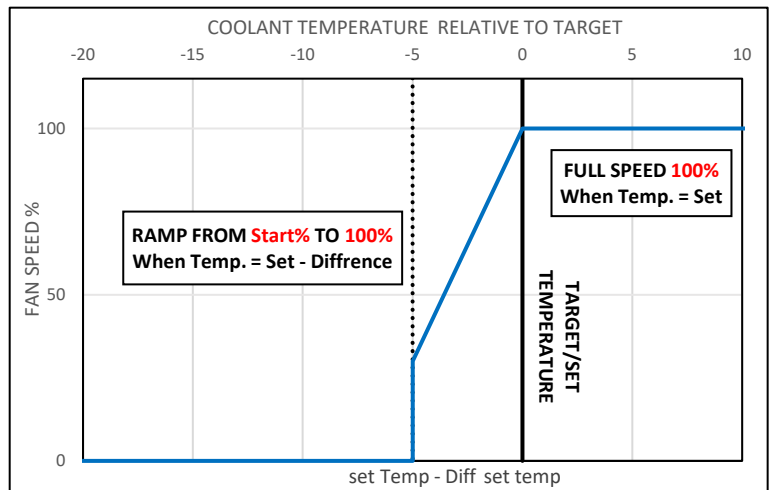

TROUBLESHOOTING GUIDE

Condition	Troubleshooting	Action
Unit does not operate	Check all the wire connections for Battery, ignition and earth	If wiring is good, replace controller
Err 1	Check sensor wiring for any short circuits	If wiring is good, replace sensor
Err 2	Check sensor wiring for any open circuits	If wiring is good, replace sensor
Temperature does not increase or has constant high temperature reading	Check sensor and sensor wiring for any damage	If wiring is good, replace sensor
Large temperature discrepancy	Check sensor and sensor wiring for any damage	If wiring is good, replace sensor

These installation instructions will suit most applications but there are circumstances surrounding some engine designs, environments, and the nature of the system involved, which may require other installation arrangements not outlined here. Frequently Asked Questions (FAQ) are listed on our website www.daviescraig.com.au . Emails can be directed to info@daviescraig.com.au or Telephone +61 (0) 3 9369 1234 during business hours.

WARRANTY

Davies, Craig Pty Ltd warrants Electric Water Pumps (EWP), Electric Booster Pumps (EBP), Controllers, Switches and Accessories for a period of three years or 2000 hours continuous running (whichever is the lesser) from the date of purchase. Davies, Craig shall carry out, free of cost, any repairs that are reasonably necessary to correct any fault in the operation of your Davies, Craig product provided that such a fault is directly attributable to a defect in the workmanship or materials used in the manufacture of the part(s). This warranty is void if the product is misused, altered, tampered with or is installed or used in a manner that is inconsistent with Davies, Craig's written recommendations and/or installation instructions. Labour and consequential costs are excluded. TPMS products carry a 1-year warranty. **DAVIES, CRAIG PTY. LTD.**

To make a warranty claim, go to: daviescraig.com.au/warranty



**DAVIES,
CRAIG**
World's best auto cooling

daviescraig.com.au

