

EWP® Combo Remote Electric Water Pump & Fan Controller Installation Instructions

Alloy EWP80, Flanged EWP80, EWP115, EWP140, & EWP150

Digital Installation instructions located here: daviescraig.com.au/instructions

**BEFORE COMMENCING INSTALLATION, PLEASE READ THESE INSTRUCTIONS THOROUGHLY.
 FAILURE TO COMPLY MAY VOID YOUR WARRANTY**

COMBO KIT COMPONENTS

All Combos		EWP®80 Flange & EWP® 140	
1	EWP® Assembly	4	Rubber Sleeve 3mm (EWP®80 Only)
1	EWP® & Dual Fan Controller	1	Straight Flange Fitting
1	Inline Adapter with Bung	1	Elbow Flange Fitting
1	10 pin Wiring Harness w/ Fuses	2	O-Ring
1	3 pin Wiring Harness	12	M5 Bolt
1	¼" NPT Thermal Sensor		
1	Controller Mounting U-Bracket		
1	Controller Mounting Plate		
4	Hose Clamps		
1	Ring Terminal		
1	Self-Tapping Screw		



EWP® Preferred Orientation

Note: The EWP® is not a self-priming water pump.

The EWP can be installed in any orientation once it is completely bled of air. the preferred orientation will assist with bleeding the pump and preventing air becoming trapped in the pump.

For The EWP80

- Avoid installing the EWP80 with the Inlet pointing vertically downward, where air can be trapped in the seal chamber.
- The ideal orientation for the EWP80 is with the inlet horizontal or on an upward angle with the outlet at the highest point.
 - This orientation is a temporary requirement for the purpose of bleeding the pump and ensuring there is no air trapped within the pump housing. The pump can be set-up in another orientation upon completion of the bleeding procedure.

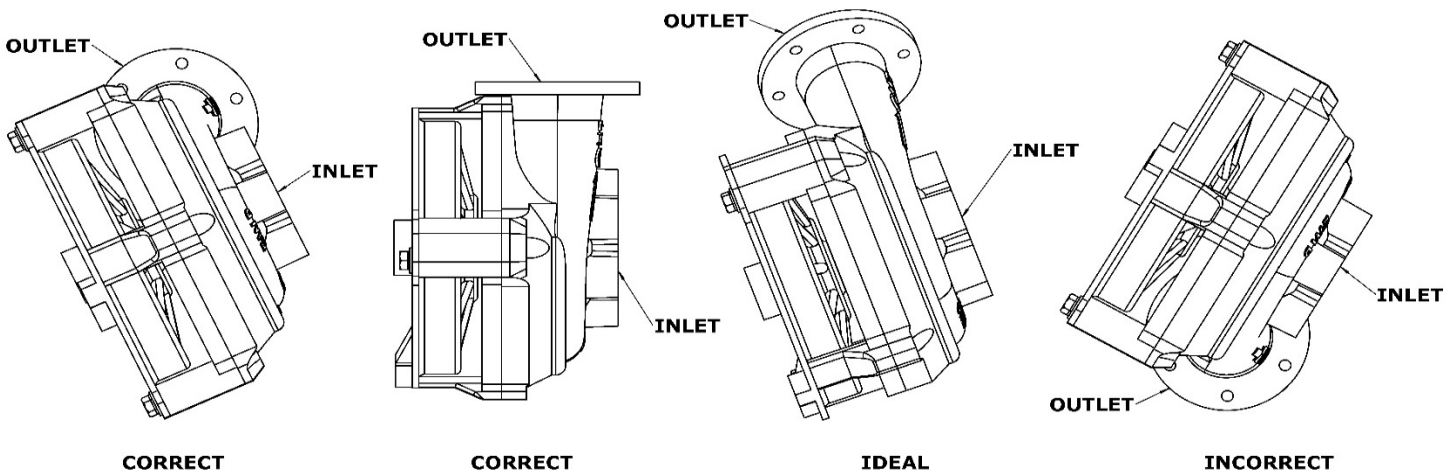

EWP80 PUMP ORIENTATION DIAGRAM

For The EWP115, EWP140 and EWP150

- ⊕ The preferred orientation for the EWP115, EWP140 and EWP150 is with the inlet horizontal or on a downward angle with the outlet at the highest point.
- ⊕ Avoid installing the EWP115, EWP140 and EWP150 with the Inlet pointing vertically Upwards. In this orientation, air can be trapped in the seal chamber.

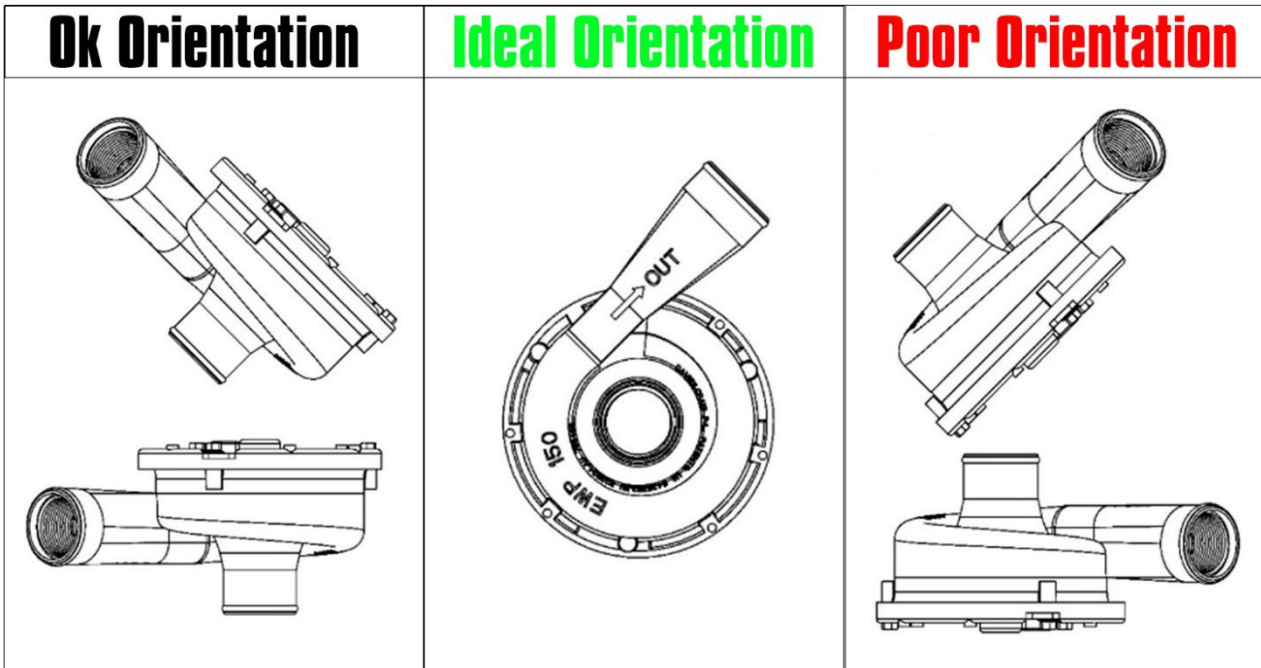

EWP® INSTALLATION

In most cases, the EWP® is adequately supported by the radiator hose. If mounting is required, it must be soft mounted to reduce vibration. For EWP115, EWP140, or EWP150, use mounting bracket Part #8700 or #8710.

- ⊕ Identify the coolant circulation direction of the system.
 - For engine cooling systems, the EWP® should be installed such that **coolant circulation direction remains unchanged.**
- ⊕ Select a suitable installation location for the EWP®.
 - For best results, the EWP® should be located low in the system and close to the outlet of the radiator, intercooler heat exchanger, or tank. (i.e. In the lower radiator hose).
 - The outlet of the EWP® should be no higher than the inlet on the engine/intercooler.
 - To avoid air locks, avoid creating high points in the radiator hose (i.e. having the hose go up and then back down). This will aid with bleeding the pump.
 - To ensure proper heater function, the heater return must be re-routed to the EWP® **INLET.**
 - Systems with an expansion/header tank require the return line routed to the EWP® **INLET.**
 - The thermostat bypass should be blocked or re-routed to the EWP® **INLET.**
 - If applicable, when using a thermostat, you must drill two approx. 3 mm (1/8") holes in the thermostat plate to allow some constant coolant circulation.
- ⊕ Install the EWP in the selected location, fill and bleed the system. Run the system to temperature and check for leaks.

AUXILIARY EWP® FOR WATER COOLED ENGINES

- ⊕ Leave the mechanical water pump in place and install the EWP® into the bottom hose.

PRIMARY EWP® FOR WATER COOLED ENGINES

- ⊕ Remove the mechanical water pump and install suitable Adapter or disengaged water pump.
 - To disengage the water pump, remove the impeller from the shaft and retain the housing. The water pump pulley can be kept as an idler to avoid re-routing the belt.
 - If required, you can also cut down the mechanical water pump housing to increase available clearance for electric fans.

Thermal Sensor Installation Options

A Davies, Craig Thermal Sensor MUST be used. The use of any other sensor will result in errors and incorrect operation.

Option 1: Inline Adapter Installation

- ⊕ Install the Thermal Sensor into the Inline Adapter, be sure not to over tighten or damage the sensor.
 - You may require some thread tape or sealant to achieve a watertight seal (Not Supplied).
- ⊕ Remove top radiator hose and confirm the inside diameter (ID) of your hose prior to cutting.
 - Rubber sleeves may be required to accommodate larger ID hose sizes.
 - ⊕ **Part #18510** – 3mm {1/8"} Rubber Sleeve increases adapter OD by 6mm (Not Supplied).
 - ⊕ **Part #18511** – 6mm {1/4"} Rubber Sleeve increases adapter OD by 12mm (Not Supplied).
- ⊕ If the parts supplied are suitable, cut approximately 20mm out of the top radiator hose and install the Inline Adapter Assembly and secure with the hose clamps.

Option 2: Threaded Port Installation

If you would prefer the Thermal Sensor may be installed into an existing port, such as the thermostat housing, Engine block, intake manifold, Radiator or Aftermarket hose adapters.

NOTE: The Thermal sensor should be installed in the **HOT** side of the cooling system

- ⊕ Install the Thermal Sensor into the port, making sure not to over tighten or damage the Thermal Sensor.
 - Thread adapter fittings (not supplied) may be required when using existing ports.
 - You need to be mindful that the location of the Thermal Sensor can affect the temperature reading and adjustments may be needed when setting the target temperature.
 - When a port is not available, it is possible to drill and tap a hole for locating the Thermal Sensor.
 - You may require some thread tape or sealant to achieve a watertight seal.

Davies, Craig has a range of alternative Inline adapters and thermal sensors available to assist with installation of the thermal sensor into factory and aftermarket sensor ports.

Optional Thermal Sensors

#18415 – 1/4" NPT Thermal Sensor (supplied)

#18418 – 1/8" NPT Thermal Sensor

#18419 – M12 x 1.5 Thermal Sensor

#18460 – Thermal sensor probe

Optional Inline Adapters

#0416 – 38mm (1-1/2 in) Inline adapter

#0419 – 35mm (1-3/8 in) Inline adapter



Thermatic® Fan Installation and Wiring

Thermatic® Fan wiring and installation hardware not included. For wiring Davies Craig Thermatic® Fan/s to the Controller we recommend using Part # 1000, #1001 for single 12V or 24V fans and Part #1002 or #1003 for dual 12V or 24V fans.

Although we recommend the use of Davies, Craig Thermatic® Fans our Controller is able to control any 12V or 24V electric cooling fan.

THERMATIC® FAN INSTALLATION

- ⊕ Install your fan/s as per the instructions included with your fan/s.
- ⊕ To wire your fan/s to the controller follow wiring instructions provided below.
 - ⊕ For Davies Craig Fans, ensure fan is rotating in direction indicated by the arrows on the fan hub.

EWP® & Dual Fan Controller Mounting

- ⊕ The Controller **MUST** be mounted inside the passenger compartment to minimise its ambient temperature and exposure to water.
- ⊕ Locate a hole in the firewall (approx. 20mm in diameter) and pass the wiring harness through (including the sensor & pump T-connector) from the passenger cabin to the engine bay.
 - Ensure all wiring is protected from rubbing on bare metal or sharp edges.

Thermal Sensor wire MUST NOT be cut in ANY circumstances.

- ⊕ Ensure the unit is mounted allowing easy access to the set buttons and to minimise exposure to direct sunlight.
- ⊕ The Controller has 2 solid mounting options to assist with your installation.
 - U-Bracket – ideal for under dash mounting
 - Mounting plate – Ideal for mounting to dash or custom brackets

EWP® & Dual Fan Controller Wiring

- ⊕ Connect the **RED** 'Battery +VE' wire to battery positive (+).
- ⊕ Connect the **BROWN** 'Earth' wire to the chassis using the self-tapping screw.
 - Ensure there is a good connection between the ring connector and chassis.
- ⊕ Connect the **YELLOW** 'Ignition' wire to an ignition controlled +12V/24V source. If necessary, the 'Ignition' wire may be spliced and soldered.
 - The ignition source must be a constant +12V/24V when the key is in the **ON** position. A manually switched +12V/24V source can also be used.
 - **DO NOT** connect the 'Ignition' wire to the ECU or the ignition coils as this can cause operational issues with the Controller or damage to the ECU.
- ⊕ To wire the controller to control Single or Twin Fans.

NOTE: The Controller will earth the 'Fan Relay' wire, it does not power it.

- Fan 1 Relay Pin 85 – connects to the **BLUE** 'Fan 1 Relay' wire.
- Fan 2 Relay Pin 85 – connects to the **ORANGE** 'Fan 2 Relay' wire.
- ⊕ Mount the 'Remote Test Light' in a location where it will be easily visible.
 - The 'Remote Test Light' may be fitted by inserting through a 4.6mm diameter hole.
 - The 'Remote Test Light' has **RED** and **BLACK** pin connectors that **MUST** be connected to the same-coloured pin connectors on the wiring harness.
- ⊕ Plug the 'Temperature Sensor' wiring into the installed Thermal Sensor.
- ⊕ Connect the T-connector from the EWP® to the 'Pump' T-Connector from the Controller wiring.
- ⊕ Plug the wiring harness into the socket of the Digital Controller.

Fan Relay Wiring

When using the Davies, Craig fan wiring harness from Part #1000, #1001, #1002 or #1003 the ring terminal on the **BLACK** wire connecting to Relay Pin 85 must be removed.

85	ORANGE or BLUE 'Fan Relay' wire
86	Battery Positive or Pin 30
30	Fused Battery Positive a fuse and holder may need installing
87	Fan wire

EWP® & Fan Override Wiring (Optional)

The controller has 3 optional override wires to manually force EWP® and fans to turn on and run continuously.

- ⊕ For Air Conditioner overrides, wire the 'Fan 1 Override' and/or 'Fan 2 Override' wires to a positive source controlled by the A/C system.
- ⊕ For manual overrides, wire the EWP®, Fan1 and Fan2 overrides to switches (Not Supplied) located in the vehicle cabin.
 - These switches need to supply the override wire with positive 12V/24V

Programming The EWP® & Dual Fan Controller

Changing Temperature Units

- ⊕ Use the '°C/°F' switch to select desired unit °C (Celsius) and °F (Fahrenheit)

Setting Pump Target Temperature

Factory set to 85°C/185°F

We recommend setting the target temperature to at least 5°C/9°F more than the rated temperature of the factory thermostat.

Method 1

- ⊕ Push the '+ Button' or '- Button' once to indicate the present temperature setting.
- ⊕ Push the '+ Button' or '- Button' again to increment the setting up (+) or down (-) one degree.
 - Hold the '+ Button' or '- Button' to continuously increment the setting Up (+) or down (-)
- ⊕ Once the desired target temperature is reached, your setting will be saved to memory after three (3) seconds if no buttons are pressed.
 - Push the 'Select Button' at any point to cancel the setting.

Method 2

- ⊕ Push the 'Select Button' once to indicate the present temperature setting.
- ⊕ Push the '+ Button' or '- Button' again to increment the setting up (+) or down (-) one degree.
- ⊕ Once the desired target temperature is reached, your setting will be saved to memory after three (3) seconds if no buttons are pressed.
 - Push the 'Select Button' at any point to cancel the setting

For Fan only applications the Pump temperature can be set to 'OFF'. When set to off the controller will not provide power to the pump or report any errors. When the Pump is turned off the Fan 1 and Fan 2 settings will become independent set temperatures

Adjusting The Screen Brightness

- ⊕ Push the 'LIGHT' to scroll between the 5 different brightness levels.

Audible Alarm

- ⊕ Us the 'ALARM' switch to turn the audible alarm buzzer on and off

Setting FAN 1 Activation Temperature

Factory set to +3°C/5°F of Pump target setting.

If Fan 1 is not being used Fan 1 activation temperature should be set to 'Off'.

- ⊕ Push the 'Select Button' twice to indicate the present activation temperature setting.
- ⊕ Push the '+ Button' or '- Button' again to increment the setting up (+) or down (-) one degree.
- ⊕ Once the desired activation temperature is reached, your setting will be saved to memory after three (3) seconds if no buttons are pressed.
 - Push the 'Select Button' at any point to cancel the setting.

Setting Fan 1 Deactivation Temperature

Factory set to -5°C/-9°F of Fan 1 activation setting.

- ⊕ Push the 'Select Button' Three times to indicate the present deactivation temperature setting.
- ⊕ Push the '+ Button' or '- Button' again to increment the setting up (+) or down (-) one degree.
- ⊕ Once the desired deactivation temperature is reached, your setting will be saved to memory after three (3) seconds if no buttons are pressed.
 - Push the 'Select Button' at any point to cancel the setting.

Setting Fan 2 Activation Temperature

Factory set to +5°C/9°F of Pump target setting.

If Fan 2 is not being used Fan 2 activation temperature should be set to 'Off'.

- ➊ Push the '**Select Button**' four times to indicate the present activation temperature setting.
- ➋ Push the '**+ Button**' or '**- Button**' again to increment the setting up (+) or down (-) one degree.
- ➌ Once the desired activation temperature is reached, your setting will be saved to memory after three (3) seconds if no buttons are pressed.
 - Push the '**Select Button**' at any point to cancel the setting.

Setting Fan 2 Deactivation Temperature

Factory set to -5°C/-9°F of Fan 2 activation setting.

- ➊ Push the '**Select Button**' five times to indicate the present deactivation temperature setting.
- ➋ Push the '**+ Button**' or '**- Button**' again to increment the setting up (+) or down (-) one degree.
- ➌ Once the desired deactivation temperature is reached, your setting will be saved to memory after three (3) seconds if no buttons are pressed.
 - Push the '**Select Button**' at any point to cancel the setting.

Setting Shutdown Temperature

Factory set to -10°C/-18°F of Pump target setting.

- ➊ Push the '**Select Button**' six times to indicate the present shutdown temperature setting.
- ➋ Push the '**+ Button**' or '**- Button**' again to increment the setting up (+) or down (-) one degree.
- ➌ Once the desired shutdown temperature is reached, your setting will be saved to memory after three (3) seconds if no buttons are pressed.
 - Push the '**Select Button**' at any point to cancel the setting.

Adjust the Temperature Sensor Offset

A temperature offset (+/- 5°C/9°F) to allow calibration of the sensor to match the OEM/other sensors in the system.

- ➊ Push and hold the '**Select Button**'.
- ➋ Push the '**+ Button**' or '**- Button**' again to increment the setting up (+) or down (-) one degree.
 - Once the desired offset temperature is reached, your setting will be saved to memory after three (3) seconds if no buttons are pressed.
 - Push the '**Select Button**' at any point to cancel the setting.

Factory Reset

Resets all settings back to default value.

- ➊ Press and hold the '**LIGHT**' and '**Select**' buttons simultaneously for 10 seconds.
 - Entire display will flash 3 times to indicate all settings have been reset to default.

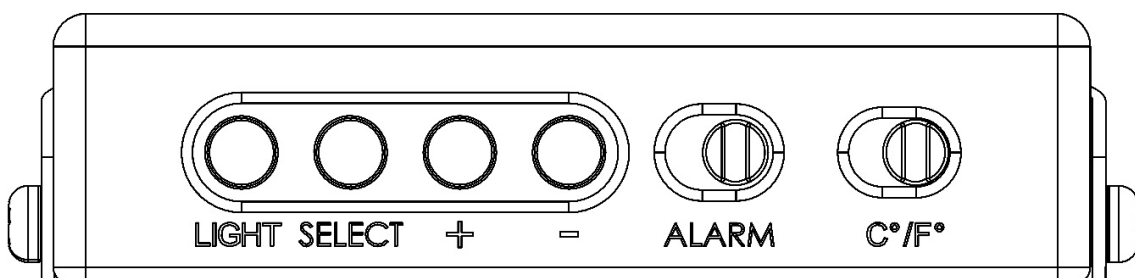

EWP® & Dual Fan Digital Controller Operation

EWP® Symbol

- ⊕ Flashing = EWP® operating in pulse mode.
- ⊕ Illuminated = EWP® running continuously.
- ⊕ Blacked out = EWP® set to "OFF"

Fan Symbol

- ⊕ Illuminated = Fan deactivated
- ⊕ Rotating = fan activated.
- ⊕ Blacked out = Fan set to "OFF"

Override Mode

- ⊕ When an override wire receives positive power, the Controller will operate your selected EWP® and/or fan/s continually until the override wire is disconnected from positive power.
- ⊕ When in Override mode the "Override Mode" indicator will light up **green** and the EWP® indicator will be illuminated and/or the Fan/s symbol will be rotating.

Shutdown Mode

- ⊕ The controller will continue to operate your EWP® and fan/s for three (3) minutes unless the coolant temperature has reduced by the shutdown temperature setting below your EWP set temperature.
 - When in shutdown mode the "Shutdown Mode" indicator will light up **green** and a 180s countdown is displayed.

Low temperature Operation

- ⊕ The controller will enter low temperature operation mode under the following conditions
 - If Temperature measurement is less the 40°C/104°F after 5 minutes
 - ❖ the controller will run the EWP at full speed
 - If Temperature measurement is still less the 40°C/104°F after 10 minutes
 - ❖ the controller will run the EWP at full speed and activate the fans.
- ⊕ The low temperature operation mode can be "snoozed" at any time by pressing any button.
 - The Snooze function will return the controller to normal operation and reset the timer.



EWP® & Dual Fan Digital Controller Operation Chart

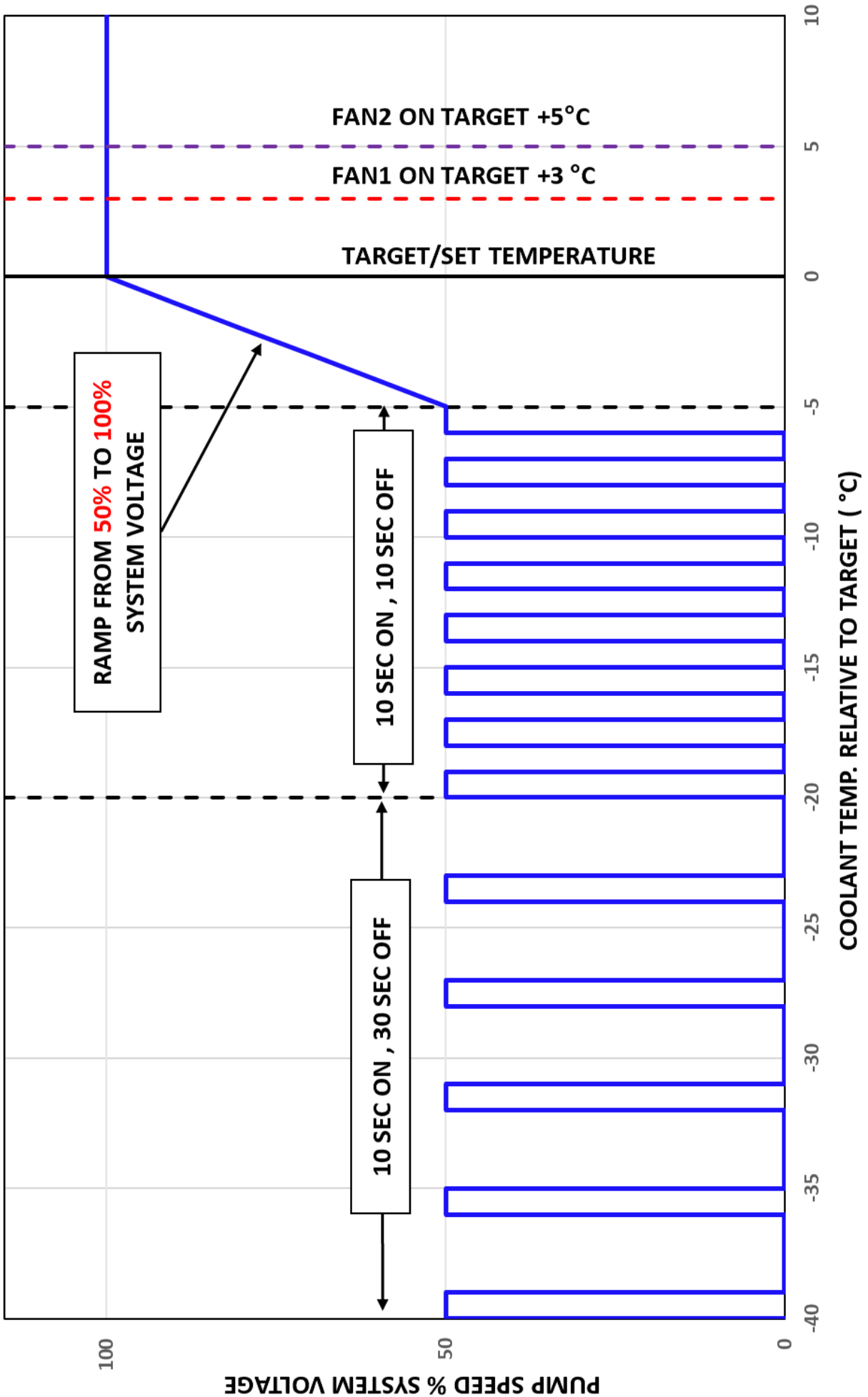

Errors and warnings

If a warning or error has been triggered. 'Remote test light' (RED LED) will flash and fault or warning indicator will light up RED.

Warnings	Condition	Controller Response
High coolant Temperature	Temperature is 5°C/9°F Above highest temperature setting	High coolant temp light on,
	Temperature is 10°C/18°F Above highest temperature setting	High coolant temp light on, Temperature flash and alarm sounds
Low coolant Temperature	Temperature is less the 40°C/104°F after 5 minutes	Pump runs at full speed continuously
	Temperature is still less the 40°C/104°F after 10 minutes	Pump and Fan/s run continuously
Low Voltage	Internal low voltage < 9V – for 12V applications Internal low voltage < 21.5V – for 24 V applications	If in shutdown mode, shutdown immediately. Otherwise continues normal operation.
Over voltage	internal high voltage > 18.5V – for 12V applications internal high voltage > 31.5V – for 24V applications	Pump and Fan/s run continuously
Sensor Short Circuit	Short circuit detected on Temperature sensor circuit	Pump and Fan/s run continuously
Sensor Open Circuit	Short circuit detected on Temperature sensor circuit	Pump and Fan/s run continuously
Pump Fault	Open circuit detected on pump circuit	Pump and Fan/s run continuously
Fan1 Error	High relay coil current draw detected on Fan 1 circuit	Fan1 circuit is shut down / turned off
Fan2 Error	High relay coil current draw detected on Fan 2 circuit	Fan2 circuit is shut down / turned off

EWP® & Dual fan Controller Specifications

Controller Specification	
Operating Voltage Range – 12V system	9V – 18V
Operating Voltage Range – 24V system	22V to 31V
Rated Continuous EWP Current Draw	10A (12A MAX)
Temperature Setting Ranges	
EWP Temperature	Off - 40°C to 110°C (104°F to 230°F)
Fan activation Temperature	Off - 0°C to +20°C (0°F to +36°F) of EWP Setting
Fan deactivation Temperature	0°C to -20°C (0°F to -36°F) of Fan Activation Setting
Shutdown Temperature	0°C to -20°C (0°F to -36°F) of EWP Setting

INSTALLATION RECOMMENDATIONS

- ⊕ It is highly recommended the EWP® is operated for at least 5 minutes constant running every month. This will minimise the build-up of any sediment in the EWP® and also lubricate all parts within the pump.
- ⊕ For some vehicles, cold climates or when running the EWP continuously you may require the use of a thermostat to help control the coolant temperature. In these cases, you will need to drill 2 x 3mm (1/8") holes in the thermostat plate.
- ⊕ The installation of an EWP® may affect coolant flow through auxiliary coolant loops and the heater core. This change in flow may affect the performance of these loops unless the return line is relocated to the EWP Inlet.
- ⊕ Block the Thermostat bypass passage, to prevent flow from your EWP passing directly back to the radiator without passing through the engine.

WARNINGS

- ⊕ Do not operate your EWP® dry as seal damage may occur, and your warranty may be jeopardised.
- ⊕ Waterless coolants increase the load on an EWP® and may reduce pump life.
- ⊕ Do not use 'stop leak' or similar leak or crack repair additives as pump damage may occur and your warranty may be jeopardised.
- ⊕ The EWP® must be completely full of coolant at all times to achieve the life and performance expectations of your EWP®.
- ⊕ The EWP® impeller tip clearance has been designed to achieve maximum efficiency and is therefore very close to the housing. When new and bedding in, the impeller may touch the internal wall of the EWP® housing causing a slight noise. This sound will cease within a very short time after the impeller has bedded in.
- ⊕ The installation of an EWP® may affect coolant flow through auxiliary coolant loops. This change in flow may affect the performance of auxiliary systems like the heater, LPG converter and Turbo cooling. In these cases, you may require an Electric Booster Pump (EBP) to provide constant flow to these systems.
- ⊕ **DO NOT ATTEMPT to tamper with the EWP including loosening or removing any bolts/screws as this will void any warranty. If you suspect there is a fault or defective product please contact Davies, Craig IMMEDIATELY.**

These installation instructions will suit most applications but there are circumstances surrounding some engine designs, environments, and the nature of the system involved, which may require other installation arrangements not outlined here. Frequently Asked Questions (FAQ) are listed on our website www.daviescraig.com.au Emails can be directed to info@daviescraig.com.au or Telephone +61 (0) 3 9369 1234 during business hours.

WARRANTY



Davies, Craig Pty Ltd warrants for a period of three years or 2000 hours continuous running (whichever is the lesser) from the date of purchase. Davies, Craig shall carry out, free of cost, any repairs that are reasonably necessary to correct any fault in the operation of your Davies, Craig product provided that such a fault is directly attributable to a defect in the workmanship or materials used in the manufacture of the part(s). This warranty is void if the product is misused, altered, tampered with, or is installed or used in a manner that is inconsistent with Davies, Craig's written recommendations and/or installation instructions. Labour and consequential costs are excluded. **DAVIES, CRAIG PTY. LTD.**

To make a warranty claim, go to: daviescraig.com.au/warranty



**DAVIES,
CRAIG**
World's best auto cooling

THE WORLD'S BEST AUTO COOLING?

Davies Craig is at the forefront of automotive cooling technology having been in the industry for over 50 years. Davies, Craig products are trusted by some of the world's leading automotive distributors and are fitted to iconic performance vehicles around the globe.

The ability to innovate and a commitment to technology, quality and service have made Davies Craig the industry leader in automotive cooling. Whatever your automotive cooling needs, Davies, Craig has the product for the job.

AUTO COOLING EXPERTS IT'S WHAT WE DO!

- ⚡ Releasing the first Thermatic® Electric Fan to the world in 1971
- ⚡ First to develop & release the Electric Water Pump in 1999
- ⚡ Global leader in quality automotive cooling patented products & ISO9001 Certified since 1994
- ⚡ Trusted by the world's leading automotive distributors.
- ⚡ Electric Water Pumps (EWP®)
- ⚡ Electric Booster Pumps (EBP)
- ⚡ Thermatic Electric Fans
- ⚡ Fan & EWP Switches / Controllers
- ⚡ Transmission / Engine Oil Coolers

daviescraig.com.au

