

## BRUSHLESS THERMATIC® FAN INSTALLATION INSTRUCTIONS

For Davies Craig: 8", 9", 10", 12", 14" and 16" Brushless Fans (12V & 24V)

Digital Installation instructions located here: <https://daviescraig.com.au/instructions>

**BEFORE COMMENCING INSTALLATION, PLEASE READ THESE INSTRUCTIONS THOROUGHLY.  
FAILURE TO COMPLY MAY VOID YOUR WARRANTY**

All Davies, Craig Brushless Thermatic® Fans include 4 mounting feet. All Davies, Craig Brushless Thermatic® Fans are designed for both **UPSTREAM** and **DOWNSTREAM** applications.

### Changing Airflow Direction for Downstream/Puller Installation

For Upstream/Pusher applications the fan blade **DOES NOT** need to be flipped.

- ➊ Remove the clip or undo the hex nut, depending on model, from the centre of the fan blade.
- ➋ Remove the fan blade from the motor shaft, turn it over and replace. In every case the instruction, printed on the blade, 'This side must face front of vehicle' and 'this side must face rear of vehicle' must be followed.
- ➌ Re-secure the fan blade.
  - ➍ For 14" and 16" fans ensure the washer is located underneath the clip
  - ➎ For 8", 9", 10" and 12" fans ensure the blade spacer remains in place with smaller diameter is towards the motor and larger diameter towards the blade.

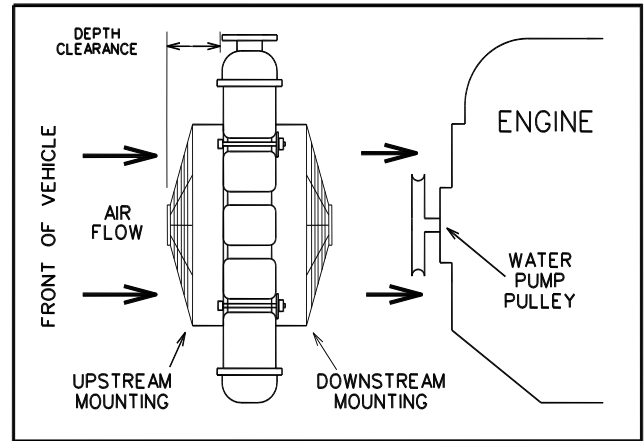

- ➏ **Ensure the hex nut is tight, if possible, torque the Hex Nut to 5 N.m (3.69 ft.lbf).**
- ➐ Before mounting the fan to the face of the radiator/condenser, note the direction of the arrow on the fan blade. The fan must rotate in the indicated direction.

### Mounting Instructions:

When mounting the fan, take care not to cause any distortion to the shroud.

**NOTE:** The small holes around the perimeter of the fan are intended for use with the Quick fit kit, not bolts. When using bolts, it is recommended to use the mounting feet (supplied) or M6 nuts inserted into the mounting feet slots.

- ➑ Take the 4 mounting feet supplied and install them onto the Fan Shroud in the desired locations around the perimeter of the shroud.
- ➒ Position the Fan against the radiator core or air conditioning condenser core.
- ➓ If using Parts #1000, #1001, #1002 or #1003 use the provided hardware to mount the fan to the core as per the instructions provided. Otherwise,
  - ➔ Quick Fit Kit Part #0579 or Mounting Hardware Part #0578 can be purchased separately.
- ➔ When installing the fan to the core don't use excessive force as this can result in damage to the core.

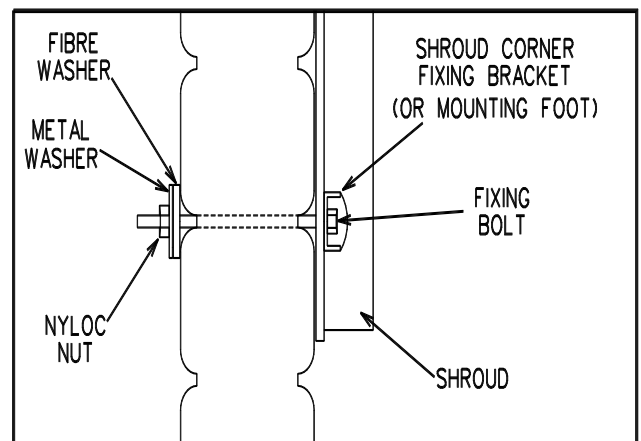

**Your Fan MUST rotate in the direction indicated by the arrow and the instruction on the hub of the fan blade "This side must face front of vehicle" must be complied with in all cases.**

# Brushless Thermatic® Fan motor control interface.

**NOTE: all 5 fan wires must be connected for the fan to operate.**

The Brushless Thermatic® fan has 9 different control modes for flexible and smart motor control. For optimal control, Davies, Craig recommends the use of a Thermatic® Fan Switch.

Davies, Craig has a full range of Thermatic® Fan Switches available in mechanical (#0401, #0404 & #0400), Digital Thermatic® Fan Switches (#0480, #0481, #0482, #0485, #0488 & #0500) and Variable Speed Controller Brushless Thermatic® Fan & EWP (#0550 & #0551). (Sold separately)

Wire		HEAVY RED	HEAVY BLACK	THIN BLACK	THIN GREEN/WHITE
Control Mode Description		Positive Supply	Negative Supply	Enable	Signal
1	On/Off – Full Speed with Switched Negative Supply	Battery Positive	Switched Negative	Negative	Positive power
2	On/Off – Full Speed with Switched Positive Supply	Switched Positive	Negative (Earth)	Negative	Positive power
3	On/Off – Full Speed with Switched Enable Signal	Battery Positive	Negative (Earth)	Switched Negative	Positive power
4	Analogue Speed Control with Switched Negative Supply	Battery Positive	Switched Negative	Negative	Analogue Voltage
5	Analogue Speed Control with Switched Positive Supply	Switched Positive	Negative (Earth)	Negative	Analogue Voltage
6	Analogue Speed Control with Switched Enable Signal	Battery Positive	Negative (Earth)	Switched Negative	Analogue Voltage
7	PWM Speed Control with Switched Negative Supply	Battery Positive	Switched Negative	Negative	PWM Signal
8	PWM Speed Control with Switched Positive Supply	Switched Positive	Negative (Earth)	Negative	PWM Signal
9	PWM Speed Control with Switched Enable Signal	Positive	Negative (Earth)	Switched Negative	PWM Signal

⬆️ For Upstream/ Pusher applications the **YELLOW** wire must be connected to **Negative**

⬆️ For Downstream/Puller applications the **YELLOW** wire must be connected to **Positive**

## Wiring to Digital Fan Switch #0480, #0481, #0482, #0485 and #0488 - Full Speed

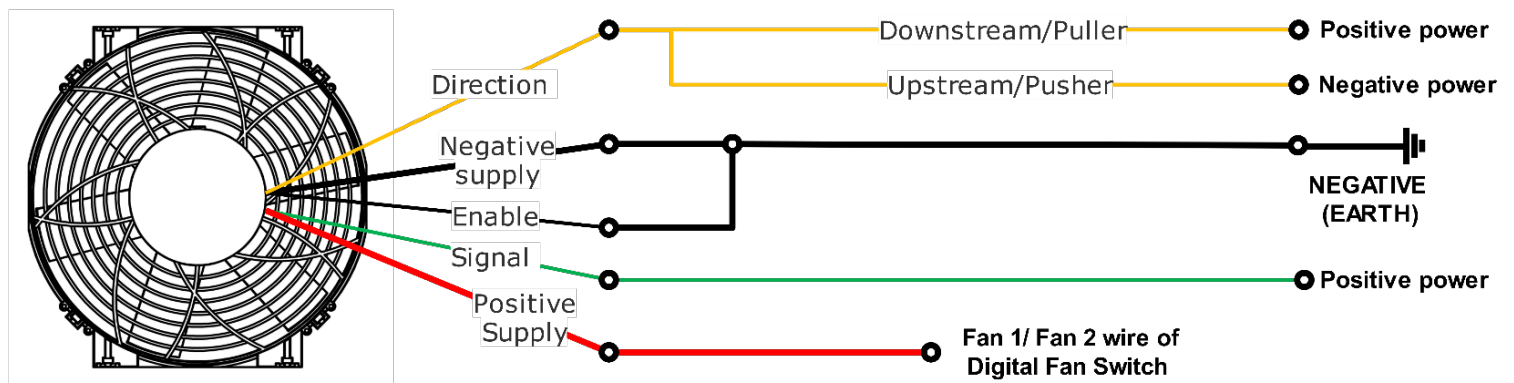

## Wiring to Variable Speed Controller Brushless Thermatic® Fan & EWP #0550 and #0551

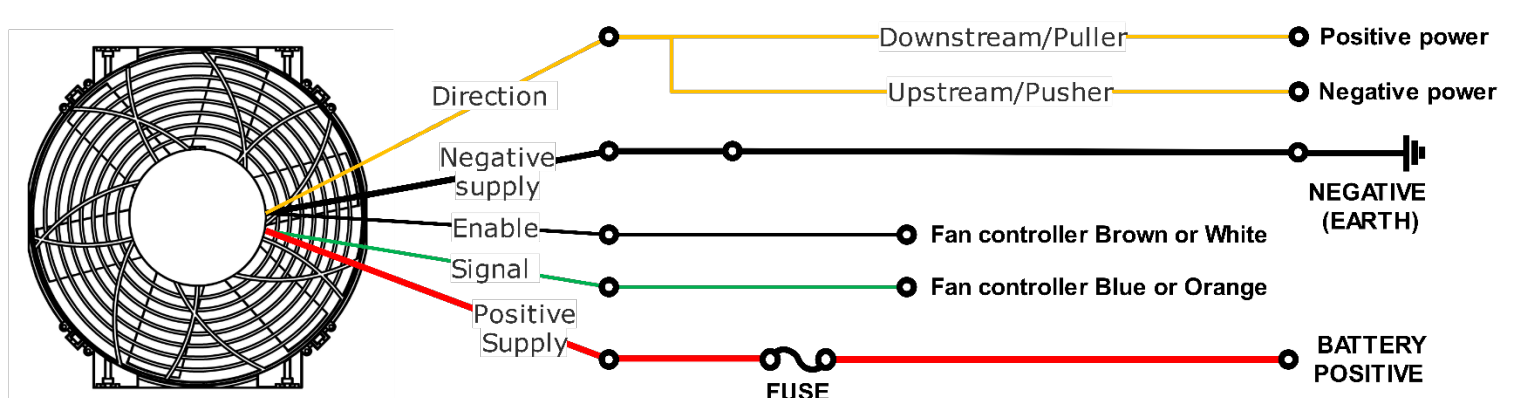

## Wiring to EWP & Fan Digital Controller #8003 – Full Speed

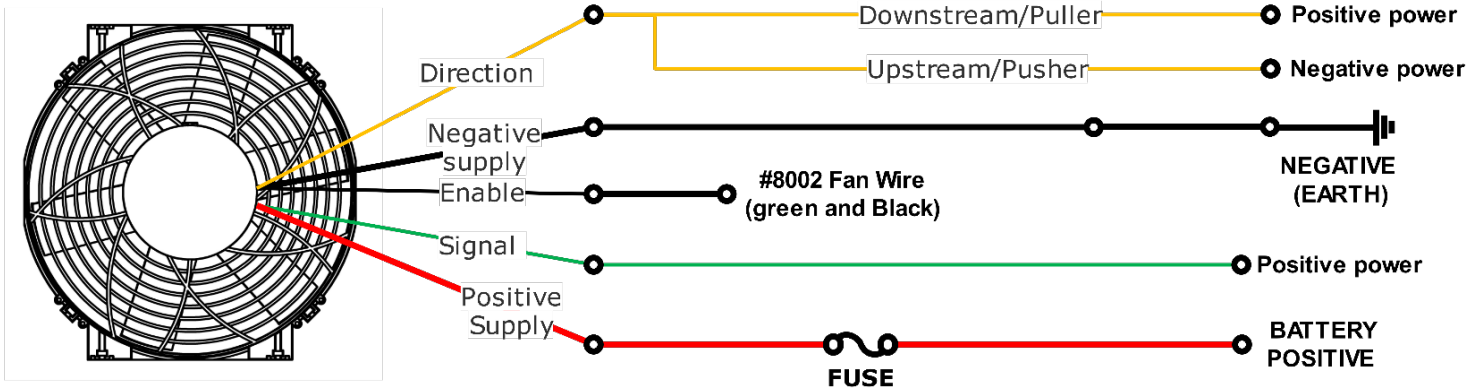

## Wiring to Digital Gauge Thematic® Fan & EWP Switch #0500 – Full Speed

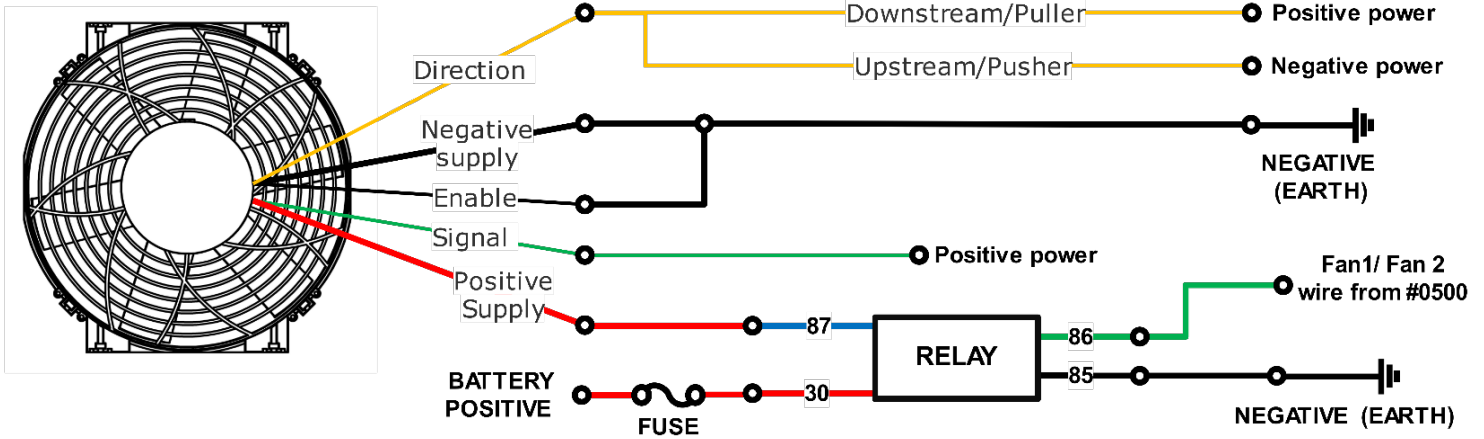

## Control Mode Wiring Diagrams – Full Speed

### Mode 1: On/Off – Full Speed with Negative Supply Wiring

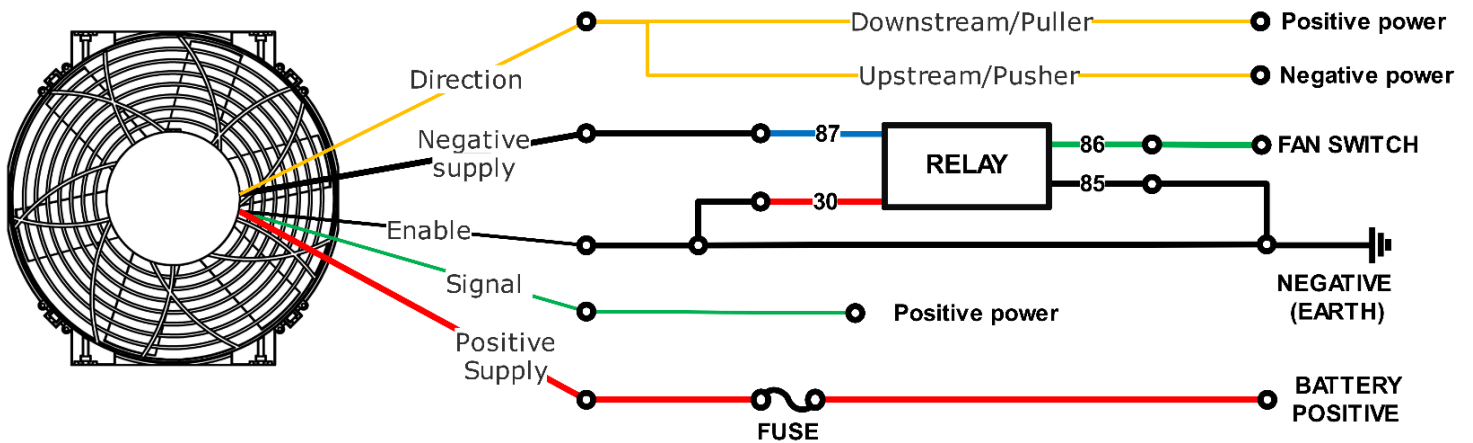

### Mode 2: On/Off – Full Speed with Switched Positive Supply Wiring

