

## Digital Thematic® Fan Switch - GEN II INSTALLATION INSTRUCTIONS

### PLEASE READ BEFORE INSTALLATION

Read these instructions completely before starting. Ensure you understand the installation before proceeding.

**Important:** This switch is configured for 12V operation. For 24V systems, replace the built-in 12V relays with 24V Relays (Part No. 10534).

### Kit Components:

#### #0480, #0481, #0482, #0483 and #0484

- ⊕ 1 x Digital Thematic Fan Switch
- ⊕ 1 x Temperature Probe Mounting Kit
- ⊕ 1 x Temperature Probe
- ⊕ 1 x ¼" NPT Thermal Sensor Kit (**#0481 only**)
- ⊕ 1 x ⅜" NPT Thermal Sensor Kit (**#0482 only**)
- ⊕ 1 x M12 x 1.5 Thermal Sensor Kit (**#0483 only**)
- ⊕ 1 x M14 x 1.5 Thermal Sensor Kit (**#0484 only**)
- ⊕ 1 x Red 6mm Ring Terminal
- ⊕ 1 x Blue 6mm Ring Terminal
- ⊕ 2 x Blue Connectors
- ⊕ 2 x Self-Tapping Screws



#### #0485 and #0488

- ⊕ 1 x Digital Thematic Fan Switch
- ⊕ 1 x Temperature Probe Mounting Kit
- ⊕ 1 x Temperature Probe
- ⊕ 1 x ¼" NPT Thermal Sensor Kit
- ⊕ 1 x Red 6mm Ring Terminal
- ⊕ 1 x Blue 6mm Ring Terminal
- ⊕ 2 x Blue Connectors
- ⊕ 2 x Self-Tapping Screws
- ⊕ 1 x 35mm Inline Adapter (**#0485 only**)
- ⊕ 1 x 38mm Inline Adapter (**#0488 only**)
- ⊕ 2 x Hose Clamp



### Switch Mounting

Mount the switch in the engine bay, in a convenient location using the self-tapping screws provided.

- **Temperature Sensor wire MUST NOT be cut in ANY circumstances.**
- Ensure the mounting location allows easy access to the set button.
- Keep unit away from high heat sources, such as exhaust manifolds etc.
- The unit is water resistant, but mounting the unit high in the engine bay is recommended.

### Option 1: Temperature Probe Installation

Requires access to the front and rear face of the radiator. Remove the radiator and/or condenser, if necessary. **The Temperature Probe MUST NOT be installed inside the radiator hose. Installing the Temperature Probe directly into coolant requires either part #0409, #0408 OR #0418.**

- ⊕ Select a Temperature Probe mounting location that will not interfere with the fan/s.
  - For optimum performance, install the Temperature Probe as close to the hot coolant inlet as possible.
  - The Temperature Probe must **not** extend through the radiator core as this will affect the switch's operation.
- ⊕ Remove the backing paper from foam pad. Slide the foam pad onto the quick mount rod so the pad adheres to the head of the quick mount rod.
- ⊕ Gently separate the radiator fins where you propose to insert the temperature probe
  - A small screwdriver can assist with this.
- ⊕ Insert the quick mount rod between the separated fins. Push the locking button and sensor onto the quick mount rod to sit flush with the face of the radiator. Cut off excess quick mount rod.

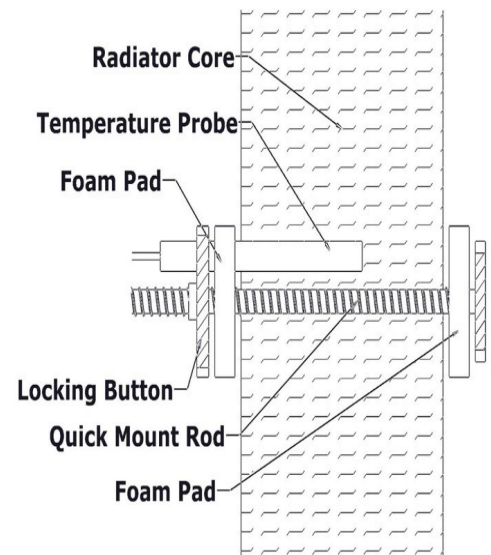

## **Option 2: Thermal Sensor Installation**

**#0480 – Temperature Probe Supplied (Requires Part No. 0462, 0464, 0465, 0468)**

**#0481 – ¼" NPT Thermal Sensor Supplied**

**#0482 – ⅛" NPT Thermal Sensor Supplied**

**#0483 – M12 x 1.5 Thermal Sensor Supplied**

**#0484 – M14 x 1.5 Thermal Sensor Supplied**

**#0485 – ¼" NPT Thermal Sensor Supplied**

**#0488 – ¼" NPT Thermal Sensor Supplied**



If you would prefer to measure the coolant temperature directly, the Thermal Sensor can be installed into the cooling system. The thermal sensor may be installed into an existing port, such as the thermostat housing, Engine block, intake manifold, Radiator or Aftermarket hose adapters. We recommend using one of our Thermal Sensors.

**NOTE:** The Thermal sensor should be installed in the HOT side of the cooling system

- ⊕ Install the Thermal Sensor into the port, making sure not to over tighten or damage the Thermal Sensor.
  - Thread adapter fittings (not supplied) may be required when using existing ports.
  - You need to be mindful that the location of the Thermal Sensor can affect the temperature reading and adjustments may be needed when setting the target temperature.
  - When a port is not available, it is possible to drill and tap a hole for locating the Thermal Sensor.
  - For ¼" NPT and ⅛" NPT You may require some thread tape or sealant to achieve a watertight seal.
  - For the M12 x 1.5 and M14 x 1.5 sensor use the supplied washer
- ⊕ Unplug the Temperature Probe and plug in the Thermal Sensor crossover cable
- ⊕ Plug in the Thermal Sensor.

## **Option 3: Installing The Thermal Sensor into the Top Hose**

**#0480 – Requires #0409 or #0408**

**#0481 – Requires #0419 or #0416**

**#0482 – Requires #18415 and #0419 or #0416**

**#0483 – Requires #18415 and #0419 or #0416**

**#0484 – Requires #18415 and #0419 or #0416**

**#0485 – ¼" NPT Thermal Sensor and 35mm inline adapter supplied**

**#0488 – ¼" NPT Thermal Sensor and 38mm inline adapter supplied**

- ⊕ Install the Thermal Sensor into the Inline Adapter, making sure not to over tighten or damage the sensor.
  - You may require some thread tape or sealant to achieve a watertight seal.
- ⊕ When the cooling system is cold, remove top radiator hose and confirm the inside diameter (ID) of your top radiator hose prior to cutting hose.
  - Rubber sleeves may be required to accommodate larger ID hose sizes.
    - ⊕ Part #18510 – 3mm {1/8"} Rubber Sleeve Increases Adapter OD by 6mm.
    - ⊕ Part #18511 – 6mm {1/4"} Rubber Sleeve Increases Adapter OD by 12mm.
- ⊕ If the parts supplied are suitable, cut approximately 20mm out of the top radiator hose and install the Inline Adapter Assembly and secure with the hose clamps.
- ⊕ Unplug the Temperature Probe from the Sensor Wires and plug in the ¼ NPT Thermal Sensor.



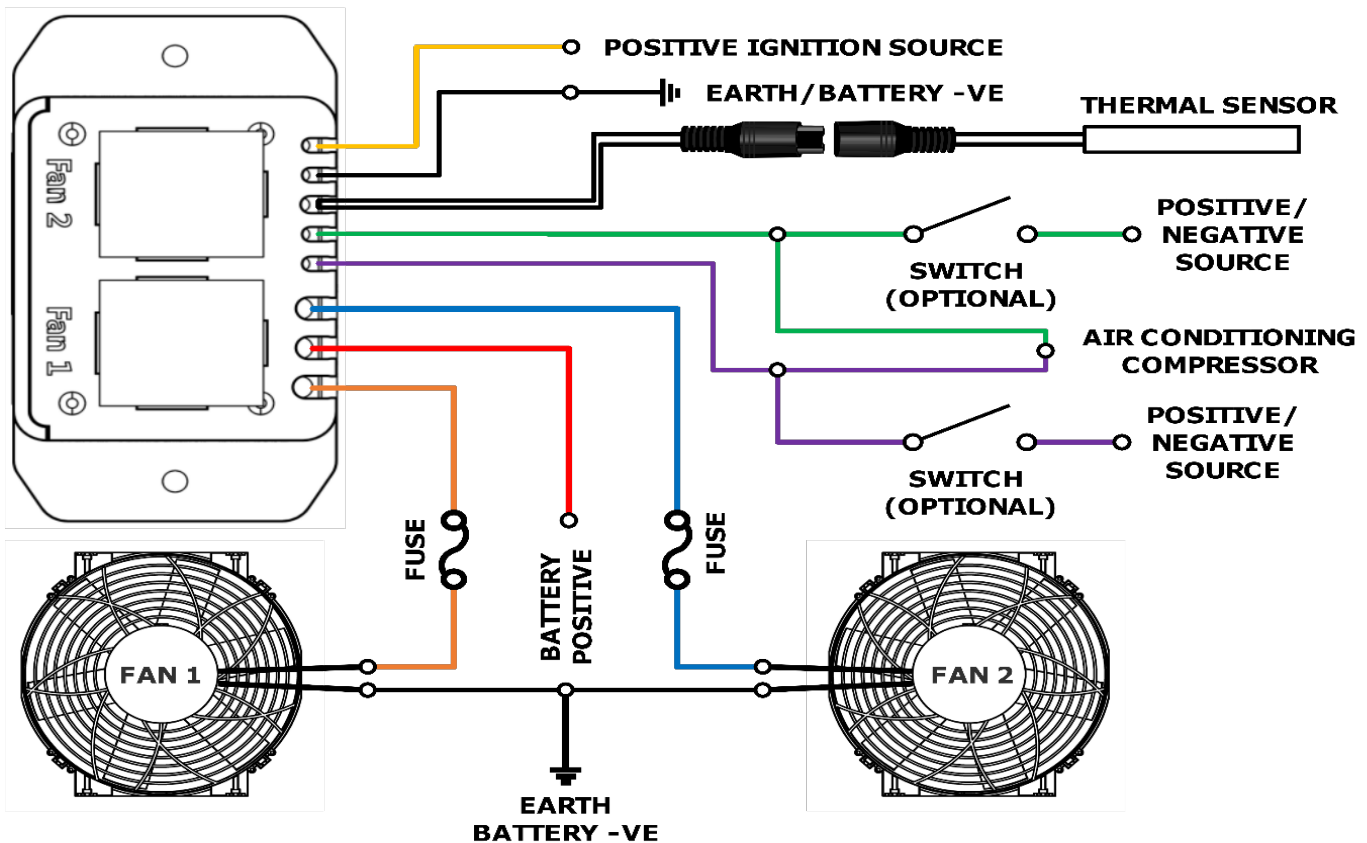

## Wiring

- ⊕ Connect the **RED** "BATTERY +VE" wire to battery positive.
  - **RED** Battery wire **does not** need require a fuse as each fan is individually fused.
- ⊕ Connect the **BLACK** "EARTH" wire to the chassis or negative Earth.
- ⊕ Connect the **YELLOW** "IGNITION" wire to a Positive ignition or accessories source.
  - DO NOT wire to the ECU or the ignition coils as this can cause operational issues
- ⊕ Connect the **ORANGE** "FAN 1" wire to Fan 1.
  - For Davies Craig Fans, ensure fan is rotating in direction indicated by the arrows on the fan hub.
  - To test the fan/s, temporarily connect the **GREEN** "OVERRIDE 1" wire to battery positive.
- ⊕ Connect the **BLUE** "FAN 2" wire to one of the wires of Fan 2.
  - For Davies Craig Fans, ensure fan is rotating in direction indicated by the arrows on the fan hub.
  - To test the fan/s, temporarily connect the **PURPLE** "OVERRIDE 2" wire to battery positive.

## Positive Earth Wiring

To wire the digital fan switch, the below changes are needed.

- ⊕ Connect the negative Fan wire to battery negative
- ⊕ Connect the **BLACK** "EARTH" wire **negative** ignition source.
- ⊕ Connect the **YELLOW** "IGNITION" wire to the chassis (**positive**).

## Air conditioning override - Optional

**NOTE:** the override signals for Fan 1 and Fan 2 can be configured for to be positive or negative, both override signals will use the selected polarity.

- ⊕ Connect the **GREEN** "OVERRIDE 1" and/or **PURPLE** "OVERRIDE 2" wire to a positive/negative source controlled by the A/C system.
  - For Dual fan system, you can choose to only wire one override to prevent both fan running with the A/C system.
  - For A/C system with a Trinary switch selecting a Negative override signal allows for direct connection to most trinary switches.

## Manual Override - Optional

- the **GREEN** "OVERRIDE 1" and/or **PURPLE** "OVERRIDE 2" wire can be used as a manual override by simply connecting it to a positive or negative source through a switch.

## Digital Fan switch Operation

Fan 1 will start at the set temperature. Fan 2 will start 5 seconds later. Both fans will operate until the temperature has been reduced to 5°C (9°F) below your set temperature.

### Setting Activation Temperature (Factory Set Temp Is 85°C = 185°F)

- Press the '**Set Button**' once to display the present temperature setting.
- Press the '**Set Button**' again to increment the set temperature by 1 degree.
  - Press and hold down the '**Set Button**' to quickly scroll through the temperature setting range.
- Stop pressing the '**Set Button**' once the desired setting is reached.
  - If you overshoot the desired setting you need to cycle through the entire setting range.
- Your setting will be saved to memory after three (3) seconds.
  - Your setting will be saved even if the unit is disconnected from power

### Temperature Setting Recommendations

- When using the Temperature probe installed in the radiator core
  - We recommend setting the temperature to approximately the factory thermostat rating.
  - The thermostat rating is the temperature it begins to open.
- When measuring the coolant temperature directly (i.e. using a Thermal Sensor)
  - We recommend setting the temperature to 10°C (18°F) above the factory thermostat rating.

If the Thermostat rating is not known, the setting can be set using the below procedure

- Start the engine and allow the coolant to reach normal operating temperature.
- Once normal operating temperature is reached set your target to 10°C (18°F) above temperature displayed.
  - Temperature measured by the Temperature Probe positioned in the radiator fins may be between 10°C & 15°C (18°F & 27°F) lower than the coolant temperature. Adjust your set temperature accordingly.

### Change Temperature Units Between: °C and °F

- Press and hold the '**Set Button**' button for 3 seconds to switch between °C & °F.

### Changing the Override Polarity (default set to Positive)

**NOTE:** the override signals for Fan 1 and Fan 2 will use the selected polarity.

- Press and hold the '**Set Button**' button for 15 seconds to display the present setting
- Continue holding '**Set Button**' the for a further 5 seconds to switch between Positive and Negative override signal polarity.
- Once the Desired Polarity is displayed (POS or NEG) release then press the '**Set Button**' to confirm your setting.
  - If the setting is not confirmed, the setting will revert to the previous setting.

Rated Voltage	12V & 24V	Errors	
Temperature Setting Range	5°C to 110°C (41°F to 230°F)	Sensor Short Circuit	Err1
Rated Continuous Current Draw	30A (40A MAX)		
MAX Start Up Current	60A	Sensor Open Circuit	Err2
Ingress Protection	IP67		

These installation instructions will suit most applications but there are circumstances surrounding some engine designs, environments, and the nature of the system involved, which may require other installation arrangements not outlined here. Frequently Asked Questions (FAQ) are listed on our website [www.daviescraig.com.au](http://www.daviescraig.com.au) . Emails can be directed to [info@daviescraig.com.au](mailto:info@daviescraig.com.au) or Telephone +61 (0) 3 9369 1234 during business hours.

## WARRANTY

Davies, Craig Pty Ltd warrants Electric Water Pumps (EWP), Electric Booster Pumps (EBP), Controllers, Switches and Accessories for a period of 3 years or 2000 hours continuous running (whichever is the lesser) from the date of purchase. Davies, Craig will carry out, free of cost, any repairs that are reasonably necessary to correct any fault in the operation of your Davies, Craig product provided that such a fault is directly attributable to a defect in the workmanship or materials used in the manufacture of the part(s). This warranty is void if the product is misused, altered, tampered with or is installed or used in a manner that is inconsistent with Davies, Craig's written recommendations and/or installation instructions. Labour and consequential costs are excluded. TPMS products carry a 1-year warranty. **DAVIES, CRAIG PTY. LTD.**

To make a warranty claim, go to: [daviescraig.com.au/warranty](http://daviescraig.com.au/warranty)